

REV.	DESCRIPTION	DRAWN	DATE
A	PRELIMINARY	FROS	2019/12/06
1	Initial release	FROS	2020/02/05
2	27.2->27.5	FROS	2021/05/25

**SPECIFICATION:**

1. Current Rating: 0.5A
2. Voltage Rating: 50VAC/ 60VDC
3. Water proof: IPX7
4. Operation Temperature: -40°C TO 85°C

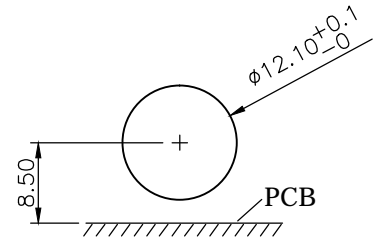

**Recommend Panel Cut**

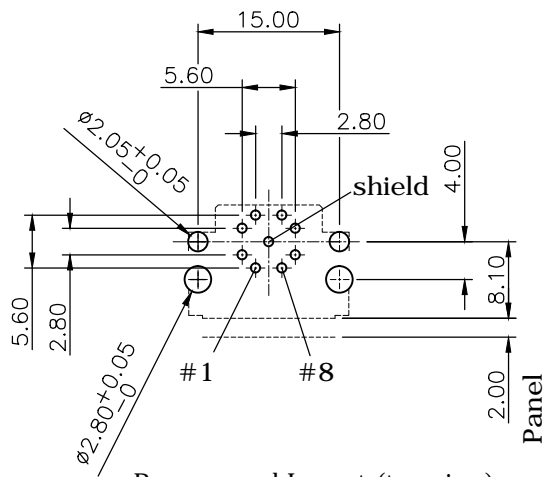
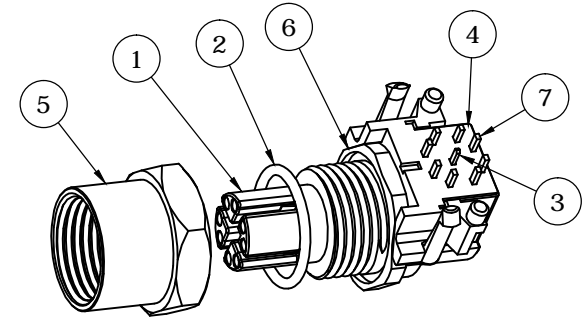
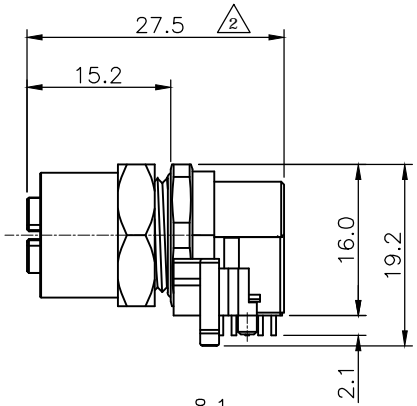
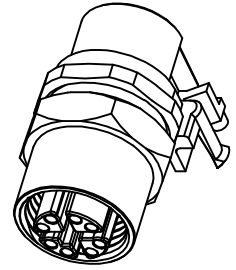
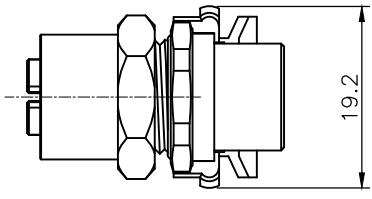
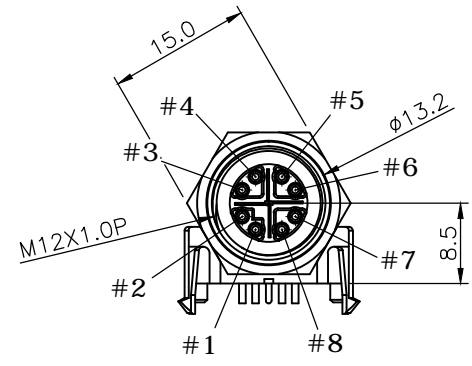

**Recommend Layout (top view)**  
General Tolerance:  $\pm 0.05\text{mm}$

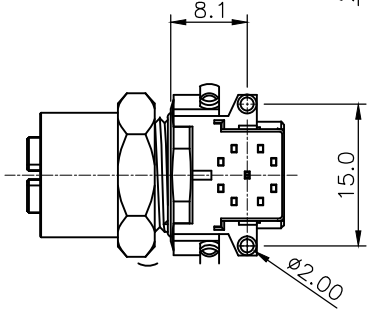

8	Glue	Epoxy
7	CONTACT	Phosphor Bronze, gold plating over nickel
6	NUT	Brass, Nickel plating
5	SCREW	Brass, Nickel plating
4	PIN HOLDER	PBT, UL94V-0, Black
3	SHIELD	Brass, Nickel plating
2	ORING	EPDM/NBR, Black
1	HOUSING	PBT, UL94V-0, Black

NO.		PART NAME		DESCRIPTION	
UNLESS OTHERWISE SPECIFIED TOLERANCE					
UNIT:	DECIMAL	LINEAR	ANGLES		 www.attend.com.tw
	mm	X	$\pm 0.50$	$\pm 5^\circ$	
		X.X	$\pm 0.25$	$\pm 3^\circ$	
		X.XX	$\pm 0.12$	$\pm 1^\circ$	
DRAWN	Fros	2019/12/06	DRAWN NAME:		
CHECKED	Tim	2019/12/06	M12 X- Code Receptacle, 8Pin Female R/A DIP Type Front Fastened		
APPROVED	Ken	2019/12/06	PRODUCT NO.	216X-08FRF	
SCALE	1.25	SHEET	1/1	SIZE	A4
			FILE NAME	216X-08FRF_B_2	