

REV.	DESCRIPTION	DRAWN	DATE
2	Add A & E Key SPEC.	FROS	2018/10/09
3	CORRECTED	TIM	2019/06/10
3.1	CORRECTED	TIM	2019/12/11

Notes:

Material:

- Housing: High Temperature Thermoplastic, UL94V-0, Black
- Contacts: Copper Alloy, gold plated on contact area and gold flash solder area. 50u" min nickel under-plating overall.
- △ Peg: Copper Alloy, 50~120u" min matte-tin plated on soldering area. 50u" min. nickel under-plating.
- Reflow Solder Capable to 260°C
- Datecode: YYWWD
- How to order:

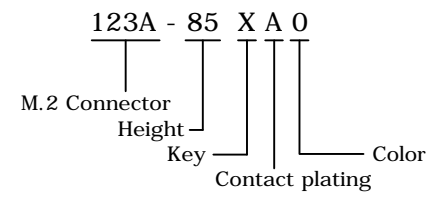

DIMENSION TABLE								
P/N	Key	DIM.A	DIM.B	DIM.C	DIM.D	DIM.E	DIM.F	DIM.G
123A-85MA0	M	-6.125	14.0	2.0	14.0	1.5	1.125	1.375
123A-85EA0	E	2.625	5.5	10.5	5.0	10.5	1.375	1.125
123A-85BA0	B	5.625	2.5	13.5	2.0	13.5	1.375	1.125
123A-85AA0	A	6.625	1.5	14.5	1.0	14.5	1.125	1.375

UNLESS OTHERWISE SPECIFIED TOLERANCE			
UNIT:	DECIMAL	LINEAR	ANGLES
mm	X.	±0.50	±5°
	X.X	±0.25	±3°
	X.XX	±0.12	±1°

DRAWN	Fros	2015/04/13	DRAWN NAME:	M2 CONNECTOR			
CHECKED	Zola	2015/04/13		A,B,E,M KEY, 0.5 PITCH, 8.5H			
APPROVED	Albert	2015/04/13	PRODUCT NO.	SEE TABLE			
SCALE	3.5	SHEET	1/6	SIZE	A4	FILE NAME	123A-85XA0_B_3.1

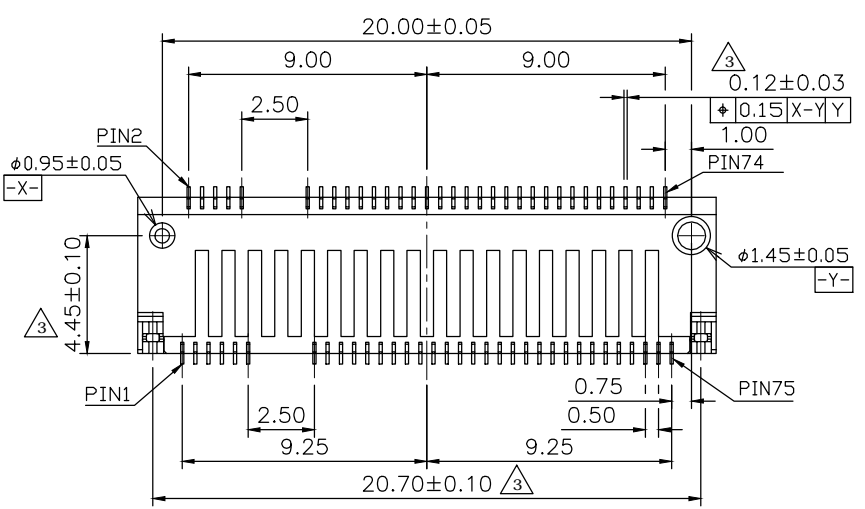
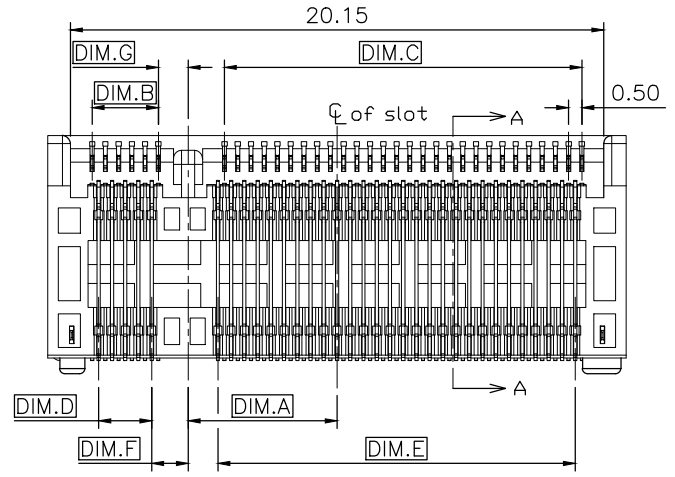
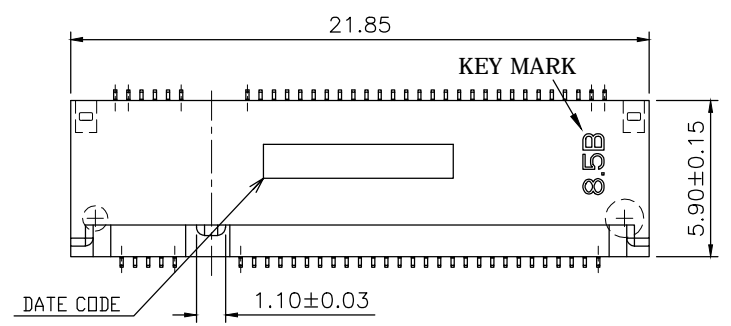
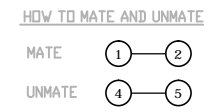
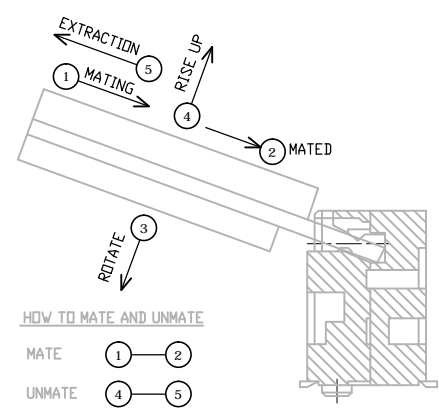
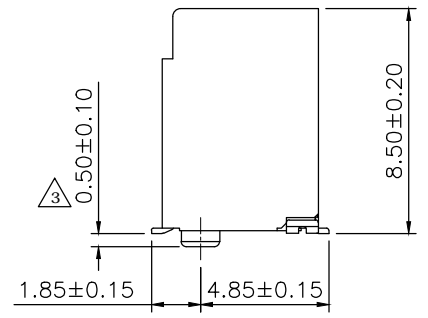
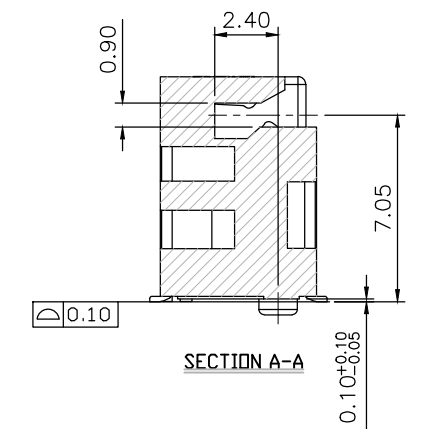

REV.	DESCRIPTION	DRAWN	DATE
	see sheet one		

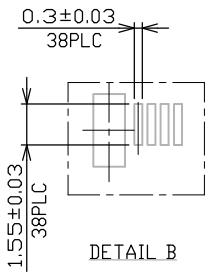
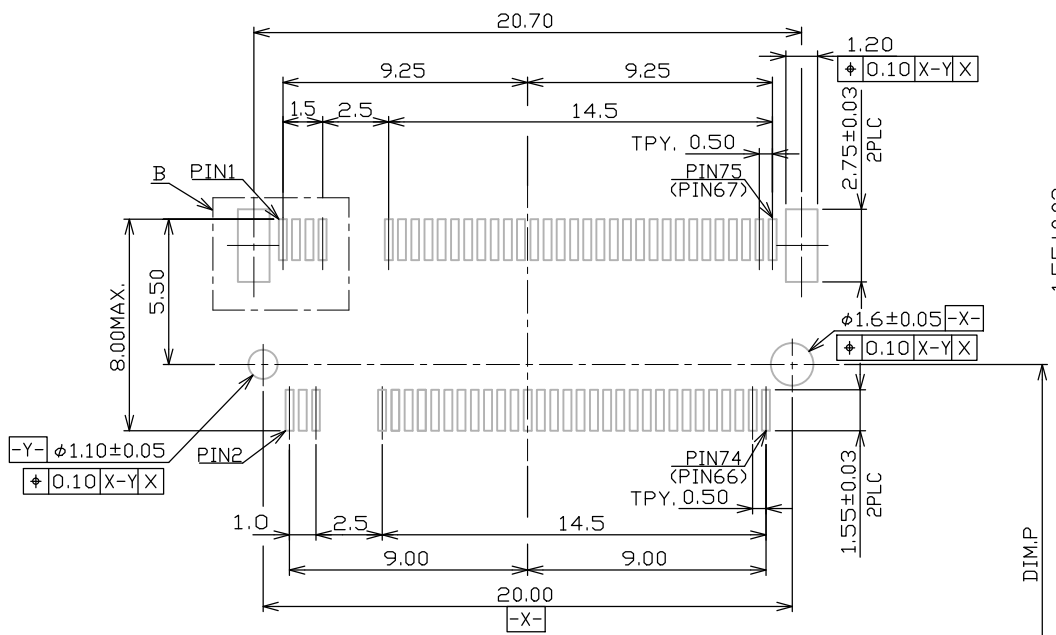
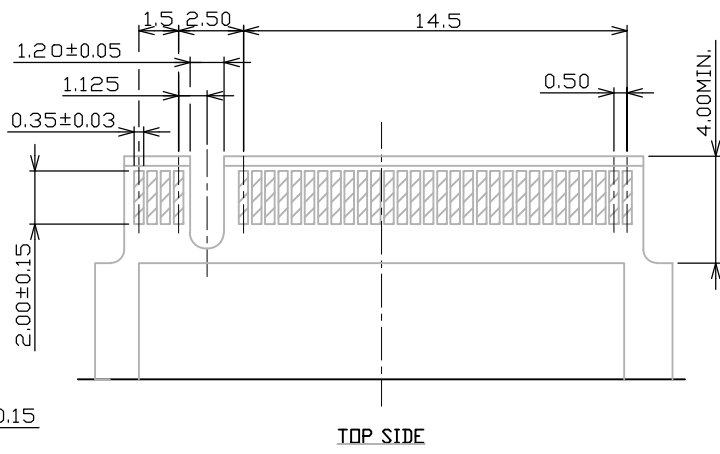
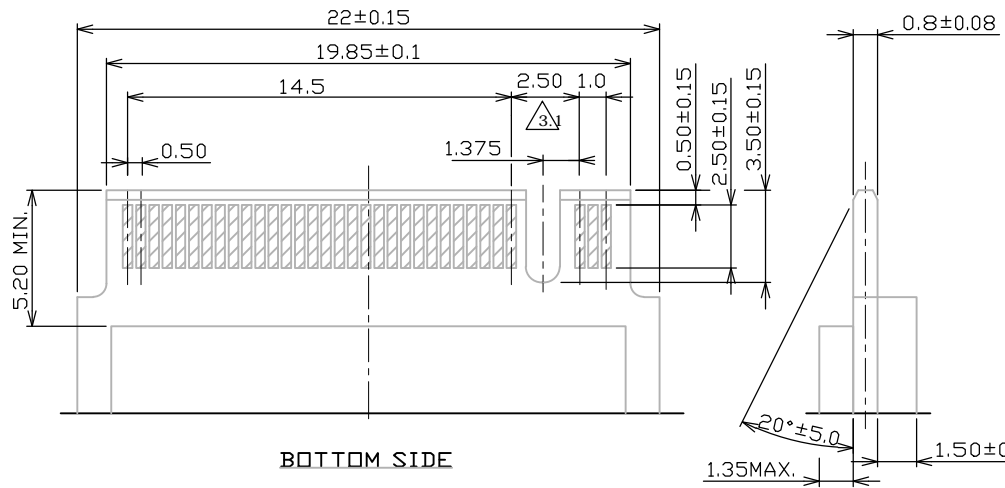

107.60	22110
77.60	2280
57.60	2260
39.60	2242
27.60	2230
39.60	3042
27.60	3030
DIM.P	MODULE TYPE

UNLESS OTHERWISE SPECIFIED TOLERANCE			
UNIT:	DECIMAL	LINEAR	ANGLES
mm	X.	±0.50	±5°
	X.X	±0.25	±3°
	X.XX	±0.12	±1°



WWW.ATTEND.COM.TW

DRAWN	Fros	2015/04/13	DRAWN NAME:
CHECKED	Zola	2015/04/13	LAYOUT, M2 CONNECTOR A-KEY, 0.5 PITCH, 8.5H
APPROVED	Albert	2015/04/13	PRODUCT NO. 123A-85AA0
SCALE	3.5	SHEET 2/6	SIZE A4
FILE NAME	123A-85XA0_B_3.1		

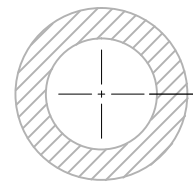

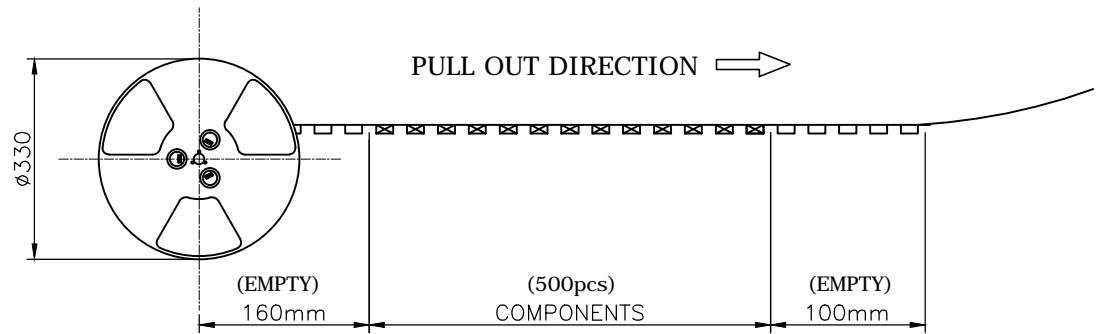

REV.	DESCRIPTION	DRAWN	DATE
	see sheet one		

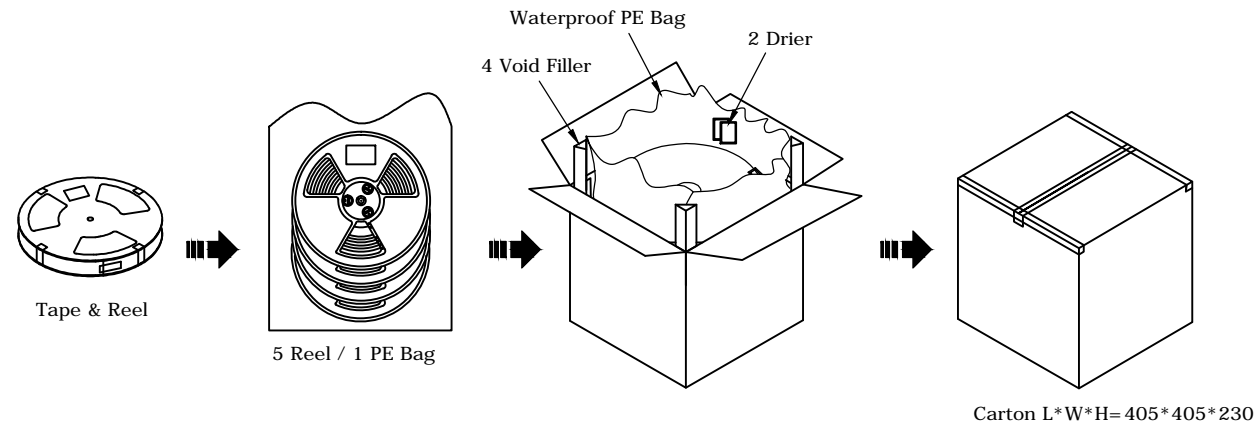
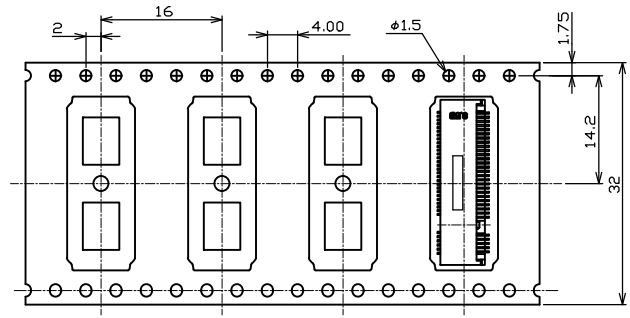

PACKAGING SPECIFICATION:

Quantity:
 500 Piece/ Reel
 5 Reel/ Carton
 2,500 Piece/ Outer Carton



UNLESS OTHERWISE SPECIFIED TOLERANCE				 WWW.ATTEND.COM.TW
UNIT:	DECIMAL	LINEAR	ANGLES	
mm	X.	±0.50	±5°	
	X.X	±0.25	±3°	
	X.XX	±0.12	±1°	
DRAWN	Fros	2015/04/13	DRAWN NAME:	
CHECKED	Zola	2015/04/13	PACKAGING, M2 CONNECTOR A,B,E,M-KEY, 0.5 PITCH, 8.5H	
APPROVED	Albert	2015/04/13	PRODUCT NO. see table	
	SCALE N/A	SHEET 6/6	SIZE A4	FILE NAME 123A-85XA0_B_3.1