

Click to
ORDER
samples

AM1DM-JZ

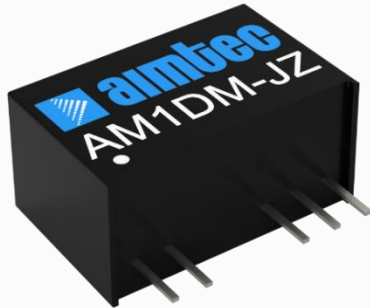

SIP7 Package

The AM1DM-JZ is a 1W SIP7 DC/DC converter that offers great cost savings thanks to an improved manufacturing process. It also features excellent reliability and performance while offering a standard input voltage range of 12-24VDC as well as an output voltage of -15 to 24V. This compact SIP7 design will surely benefit your new system design.

This new series offers great operating temperatures, from -40 to 105°C with full power up to 85°C. Also, an isolation of 5000VAC or 6000VDC for improved reliability and system safety as well as a great 19,360,000h MTBF come standard.

The AM1DM-JZ is suitable for many applications such as medical collection isolation, high voltage collection circuits, and IGBT drive circuits.

Features

- High I/O Isolation of 5000VAC or 6000VDC
- Continuous Short circuit protection
- Operating Temp: -40 °C to +105 °C
- Industry standard SIP7 pin-out
- Efficiency up to 83%
- Unregulated output
- Leakage current < 2µA
- Meets EN60601-1, ANSI/AAMI ES60601-1 standard (1xMOPP & 2xMOOP)
- Meets IEC62368 standard



Summary

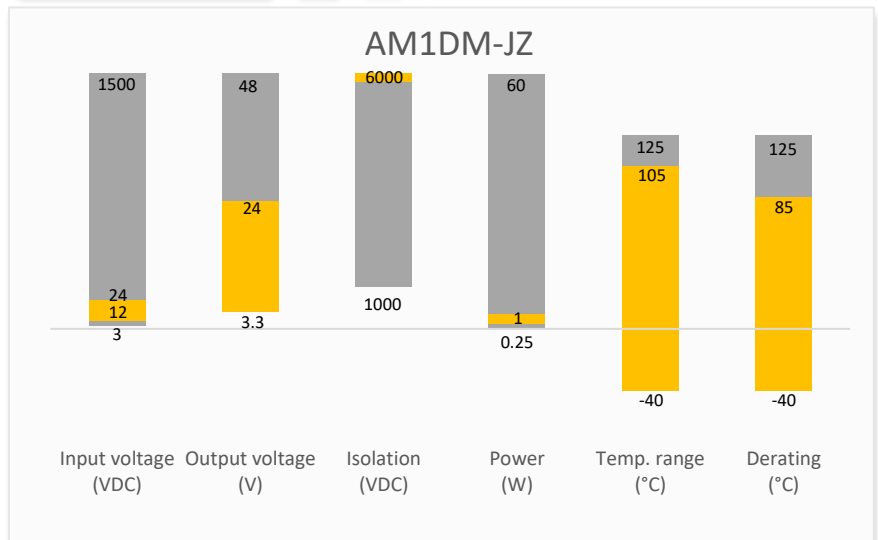

Training



Product Training Video
(click to open)



Press Release

Coming Soon!

Application Notes

Applications



Industrial



Portable Equipment



Medical



IoT

Models & Specifications



Single Output

Model	Input Voltage (VDC)	Output Voltage (VDC)	Input Current Full No load typ. (mA)	Output Current max min (mA)*	Isolation (VDC)	Maximum capacitive Load (μF)	Efficiency Typ. (%)
AM1DM-1203SH60JZ	12 (10.8-13.2)	3.3	106 / 10	303 / 31	6000	2200	76
AM1DM-1205SH60JZ	12 (10.8-13.2)	5	106 / 10	200 / 20	6000	2200	79
AM1DM-1209SH60JZ	12 (10.8-13.2)	9	106 / 10	111 / 12	6000	680	81
AM1DM-1212SH60JZ	12 (10.8-13.2)	12	106 / 10	84 / 9	6000	470	83
AM1DM-1215SH60JZ	12 (10.8-13.2)	15	106 / 10	67 / 7	6000	470	83
AM1DM-1224SH60JZ	12 (10.8-13.2)	24	106 / 10	42 / 4	6000	220	82
AM1DM-2405SH60JZ	24 (21.6-26.4)	5	56 / 12	200 / 20	6000	2200	76
AM1DM-2409SH60JZ	24 (21.6-26.4)	9	56 / 12	111 / 12	6000	680	76
AM1DM-2412SH60JZ	24 (21.6-26.4)	12	56 / 12	84 / 9	6000	470	76
AM1DM-2415SH60JZ	24 (21.6-26.4)	15	56 / 12	67 / 7	6000	470	76
AM1DM-2424SH60JZ	24 (21.6-26.4)	24	56 / 12	42 / 4	6000	220	76

* Performance will be degraded if the load is not within the output current range.

Dual Output

Model	Input Voltage (VDC)	Output Voltage (VDC)	Input Current Full No load typ. (mA)	Output Current max min (mA)*	Isolation (VDC)	Maximum capacitive Load (μF)	Efficiency Typ. (%)
AM1DM-1205DH60JZ	12 (10.8-13.2)	±5	106 / 10	±100 / ±10	6000	1000	79
AM1DM-1209DH60JZ	12 (10.8-13.2)	±9	106 / 10	±56 / ±6	6000	470	79
AM1DM-1212DH60JZ	12 (10.8-13.2)	±12	106 / 10	±42 / ±5	6000	200	81
AM1DM-1215DH60JZ	12 (10.8-13.2)	±15	106 / 10	±34 / ±4	6000	200	81
AM1DM-1505DH60JZ	15 (13.5-16.5)	±5	90 / 10	±100 / ±10	6000	1000	77
AM1DM-1512DH60JZ	15 (13.5-16.5)	±12	90 / 10	±42 / ±5	6000	220	79
AM1DM-1515DH60JZ	15 (13.5-16.5)	±15	90 / 10	±34 / ±4	6000	220	79
AM1DM-2405DH60JZ	24 (21.6-26.4)	±5	56 / 12	±100 / ±10	6000	1000	75
AM1DM-2409DH60JZ	24 (21.6-26.4)	±9	56 / 12	±56 / ±6	6000	470	75
AM1DM-2412DH60JZ	24 (21.6-26.4)	±12	56 / 12	±42 / ±5	6000	220	76
AM1DM-2415DH60JZ	24 (21.6-26.4)	±15	56 / 12	±34 / ±4	6000	220	76

* Performance will be degraded if the load is not within the output current range.

Input Specification

Parameters	Conditions	Typical	Maximum	Units
Filter	Capacitor			
Absolute maximum rating	Maximum duration 1s, 12Vin	> -0.7	18	VDC
	Maximum duration 1s, 15Vin	> -0.7	21	VDC
	Maximum duration 1s, 24Vin	> -0.7	30	VDC
Input reflected ripple current		200		mA
Hot Plug		Unavailable		

Isolation Specification				
Parameters	Conditions	Typical	Maximum	Units
Tested I/O voltage	60 sec, leakage \leq 1mA	5000		VAC
		6000		VDC
Patient leakage current	250VAC, 50/60Hz		2	μ A
Resistance	500VDC	>1000		M Ω
Capacitance	100kHz/0.1V	4		pF

Output Specification				
Parameters	Conditions	Typical	Maximum	Units
Voltage accuracy		See output voltage tolerance		
Line regulation	Per 1% Vin change, 3.3Vout models		1.5	
	Per 1% Vin change, other models		1.2	
Load regulation	10-100% load, 3.3V/5V output models		20	%
	10-100% load, other output models		15	%
Ripple & Noise*	3.3V output models	100	150	mV p-p
	Other output models	80	120	mV p-p
Temperature coefficient	100% full load	\pm 0.02		%/°C

* Ripple and Noise are measured at 20MHz bandwidth. Please refer to the application note for specific details.

General Specifications				
Parameters	Conditions	Typical	Maximum	Units
Switching frequency	100% load, nominal input voltage	200		KHz
Short circuit protection	Continuous, Auto recovery			
Operating temperature	Derating when operating temperature \geq 85°C	-40 to +105		°C
Storage temperature		-55 to +125		°C
Case temperature rise	Ta = 25°C	25		°C
Manual soldering temperature	1.5mm away from case, duration \leq 10sec		300	°C
Cooling	Free air convection			
Humidity	Non-condensing	>5	95	% RH
Case material	Black plastic (flammability to UL 94V-0)			
Weight		4.0		g
Dimensions (L x W x H)	0.77 x 0.39 x 0.49 inches (19.50 x 9.80 x 12.50 mm)			
MTBF	19 360 000 hrs (MIL-HDBK -217F, t _a =+25°C) / Full Load			
Creepage & clearance distance	Minimum of 5 mm			

NOTE: All specifications in this datasheet are measured at an ambient temperature of 25°C, humidity<75%, nominal input voltage and at rated output load unless otherwise specified.

Safety Specifications		
Parameters		
Standards	Information technology equipment	Designed to meet IEC/EN62368-1
	EMC - Conducted and radiated emission	CISPR32 / EN55032, class B with the recommended EMI circuit EN60601-1-2/CISPR 11 GROUP1 class B with the recommended EMI circuit
	Electrostatic Discharge Immunity	EN60601-1-2 (IEC 61000-4-2) Air \pm 15KV, Contact \pm 8KV, Criteria B

Derating

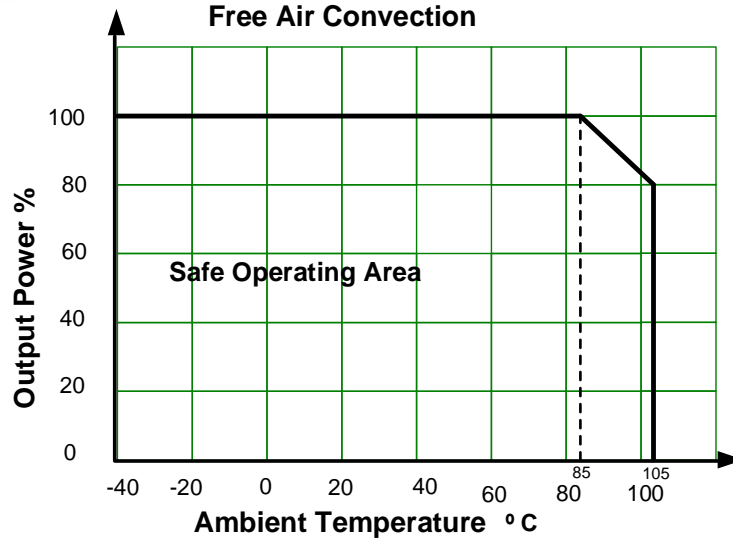

Output voltage tolerance

AM1DM-1203SH60JZ

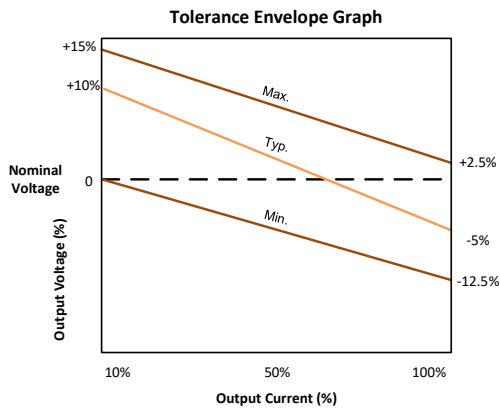

5VDC output models

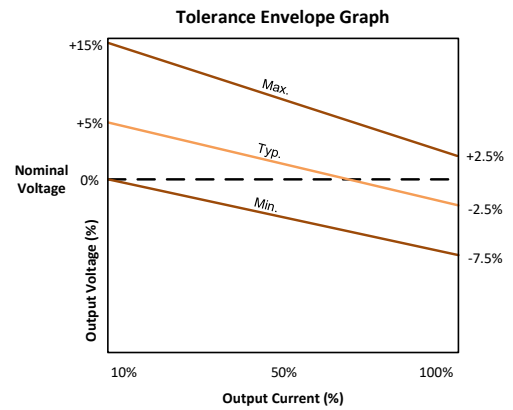

Other Voltage output models

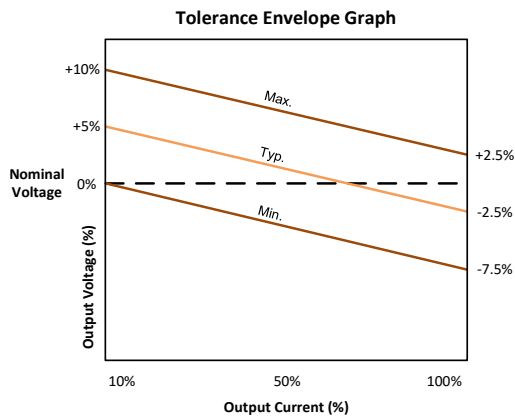

Typical application circuit

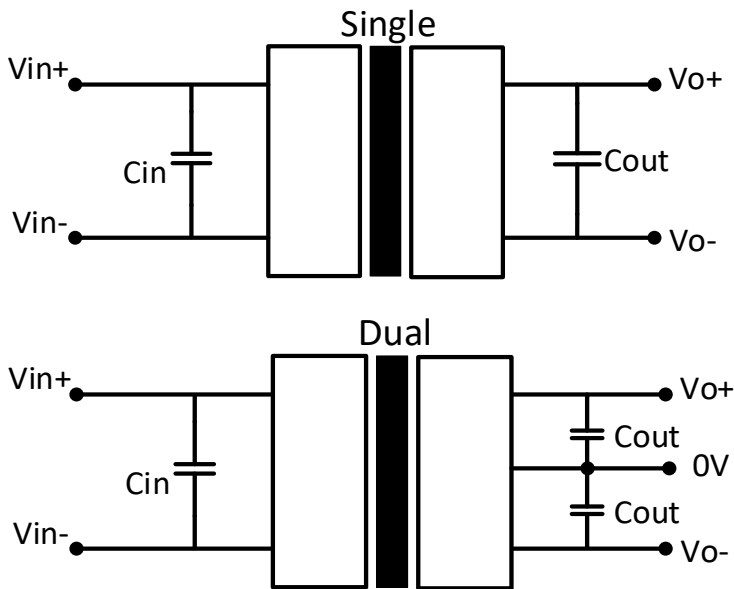

V_{in}	C_{in}
12VDC	10 μ F/25V
15VDC	1 μ F/25V
24VDC	2.2 μ F/50V

V_{out}	C_{out}
3.3/5VDC	10 μ F/16V
9VDC	10 μ F/16V
12VDC	2.2 μ F/25V
15VDC	1 μ F/25V
24VDC	0.47 μ F/50V

Dual V_{out}	C_{out}
$\pm 5/\pm 9$ VDC	4.7 μ F/16V
$\pm 12/\pm 15$ VDC	1 μ F/25V

Table 1

Recommended EMI circuit

12V/15V input

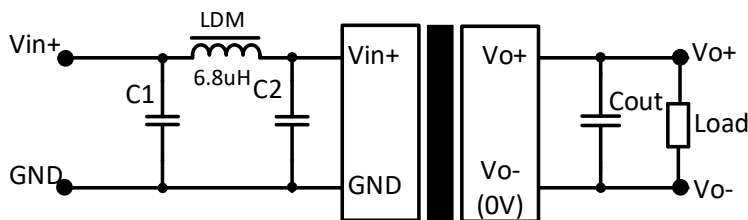

Input Voltage		12/15 VDC
Emissions	C_1/C_2	4.7 μ F/25V
	C_{out}	Reference C_{out} in Table 1
	LDM	22 μ H

24V input

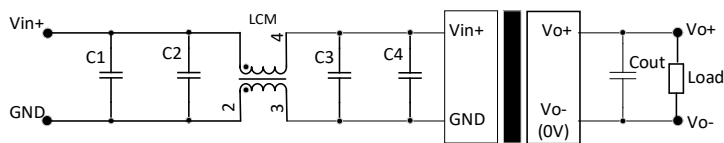

Input Voltage		24 VDC	
Emissions	C_1/C_2	4.7 μ F/50V	
	C_3	AM1DM-24_DH60JZ	100 μ F/50V
		Other output	4.7 μ F/50V
	C_4	AM1DM-24_DH60JZ	--
		Other output	4.7 μ F/50V
	C_{out}	Reference C_{out} in Table 1	
LCM	22 μ H (Nickel zinc inductance)		

Dimensions

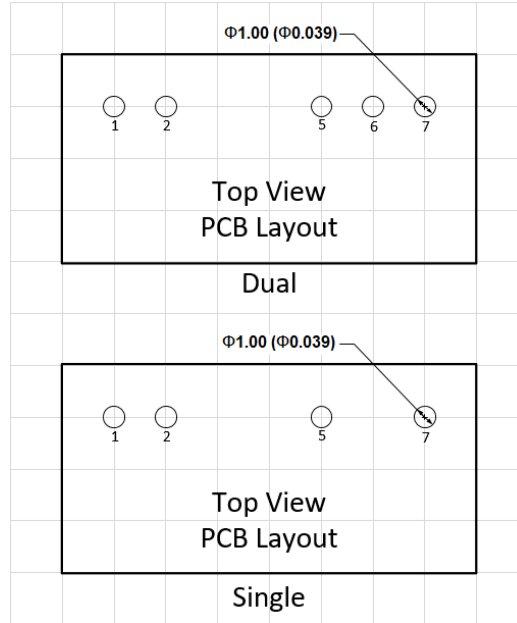
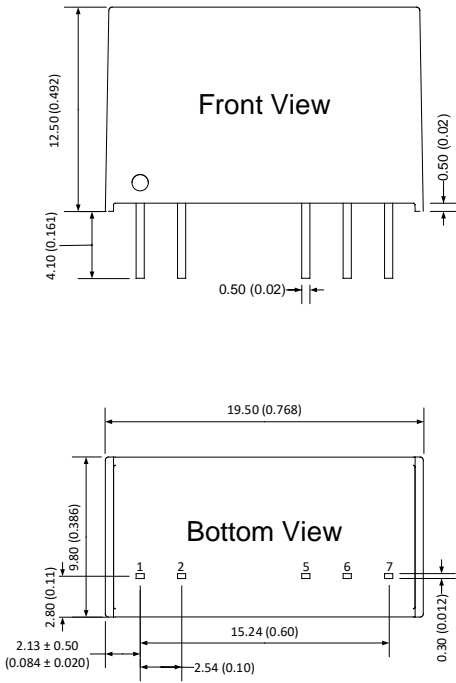

Pin Out Specifications		
Pin	Single output	Dual output
1	+V Input	+V Input
2	-V Input	-V Input
5	-V Output	-V Output
6	No pin	Common
7	+V Output	+V Output

Note:
Grid 2.54 x 2.54mm
Unit: mm(inch)
Pin section tolerances: $\pm 0.10(\pm 0.004)$
General tolerances: $\pm 0.50(\pm 0.020)$

NOTE: **1.** Datasheets are updated as needed and as such, specifications are subject to change without notice. Once printed or downloaded, datasheets are no longer controlled by Aimtec; refer to www.aimtec.com for the most current product specifications. **2.** Product labels shown, including safety agency certifications on labels, may vary based on the date manufactured. **3.** Mechanical drawings and specifications are for reference only. **4.** All specifications are measured at an ambient temperature of 25°C, humidity<75%, nominal input voltage and at rated output load unless otherwise specified. **5.** Aimtec may not have conducted destructive testing or chemical analysis on all internal components and chemicals at the time of publishing this document. CAS numbers and other limited information are considered proprietary and may not be available for release. **6.** This product is not designed for use in critical life support systems, equipment used in hazardous environments, nuclear control systems or other such applications which necessitate specific safety and regulatory standards other the ones listed in this datasheet. **7.** Warranty is in accordance with Aimtec's standard Terms of Sale available at www.aimtec.com.