

REV.	DESCRIPTION	DRAWN	DATE
------	-------------	-------	------

Specification :

Item	Parameter	Condition	Min.	Typ.	Max.	Unit	REMARK
1	Insertion loss	1-100 MHz			-1	dB	
2	Return loss	1-30 MHz	-16			dB	NOTE 1
		30-60 MHz				dB	
		60-80 MHz	-10			dB	
3	□CL	100 KHz	350			μH	
4	Crosstalk	1-100 MHz	-35			dB	
5	Hipot	Vrms	1.5			kV	
6	Turns Ratio (Chip : Cable)	TX: 1 : 1 RX: 1 : 1				CT	
7	Direct Current resistance					Ω	

*NOTE 1: Greater than $(16-20 \text{ Log } (f/30\text{MHz}))$ dB.

CONNECTOR SOLDER SIDE

RJ45
CONTACT SIDE

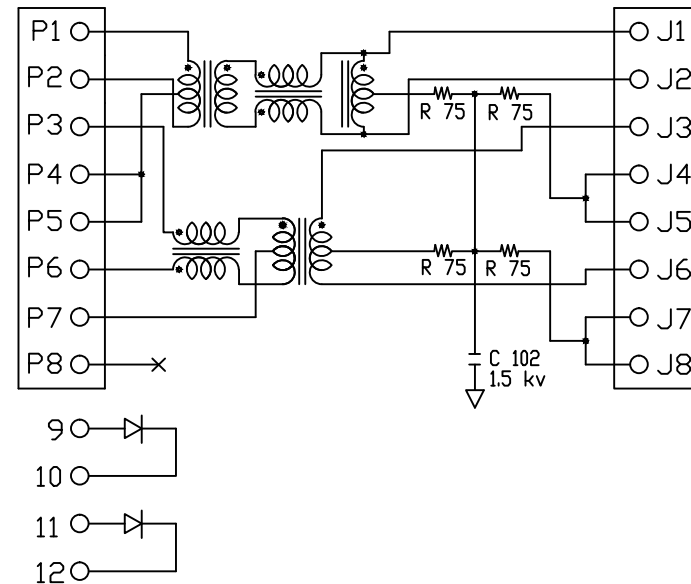

CONNECTOR SCHEMATIC

UNLESS OTHERWISE SPECIFIED TOLERANCE				 www.attend.com.tw			
UNIT:	DECIMAL	LINEAR	ANGLES			DRAWN: Willis 2013/06/13 DRAWN NAME: RJ45 1X2 Jack Magnetic Type CHECKED: Angel 2013/06/13 APPROVED: Ken 2013/06/13 PRODUCT NO. 213A-12CXA-RA12 SCALE 1/1 SHEET 2/2 SIZE A4 FILE NAME 213A-12CXA-RA12_B_2	
mm	X.	±0.50	±5°				
	X.X	±0.25	±3°				
	X.XX	±0.12	±1°				