

THIS DRAWING IS UNPUBLISHED. RELEASED FOR PUBLICATION
 © COPYRIGHT - By - ALL RIGHTS RESERVED.

| REVISIONS | | | | |
|-----------|---------------|-------------|----------|---------|
| P | LTR | DESCRIPTION | DATE | APVD |
| P1 | ECR-16-004636 | | 16-06-30 | T.Q W.H |

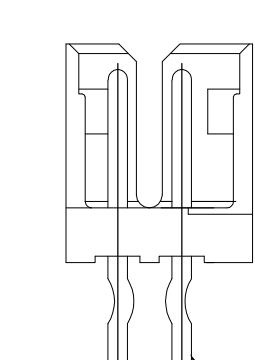
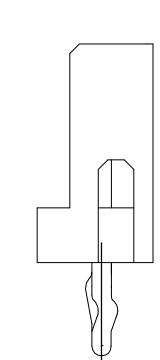
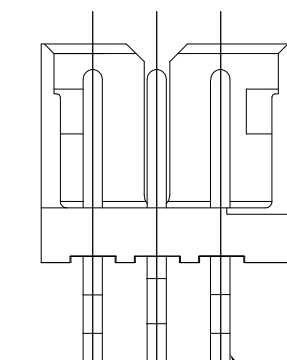
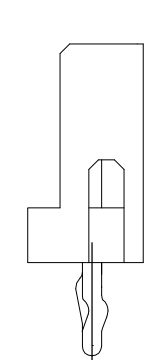
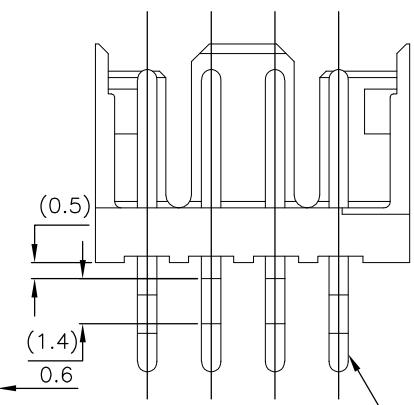
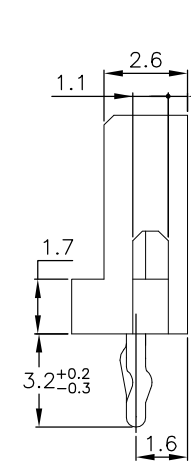
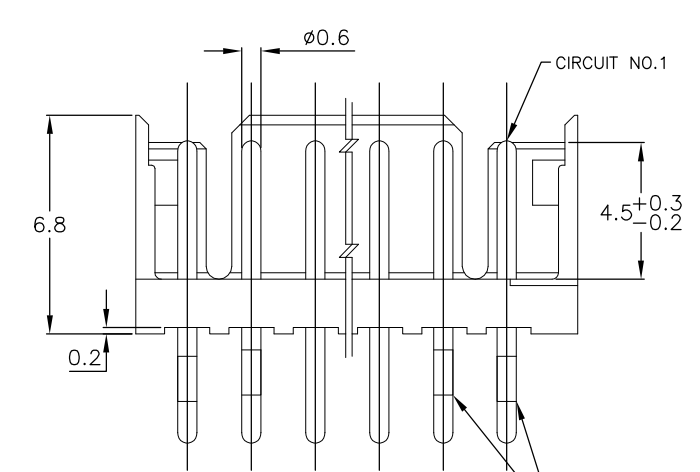
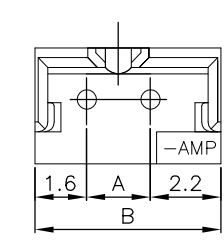
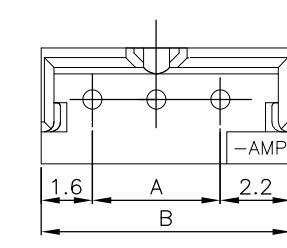
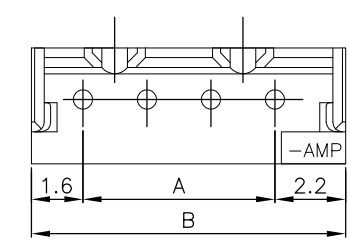
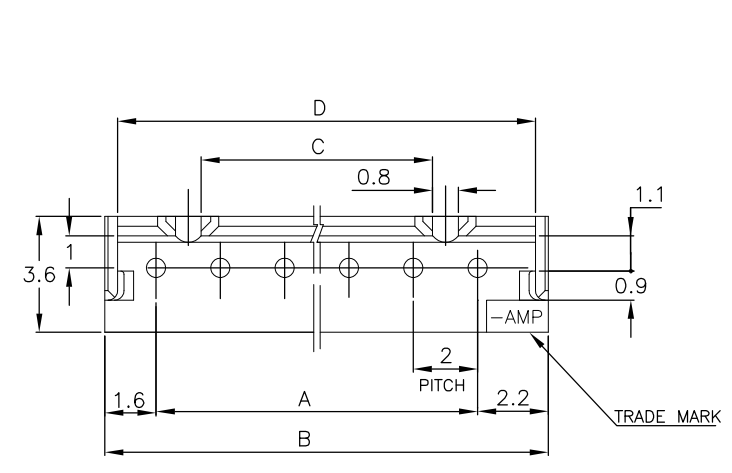

5~15 Pos.

4 POS.

3 POS.

2 POS.

NOTES:

- 1.MATERIAL: HOUSING - NYLON 66 (UL94V-0)
POST - TIN BRASS
- 2.APPLICABLE RECEPTACLE P/N 173977
- 3.OBSOLETE RED COLOR PARTS.

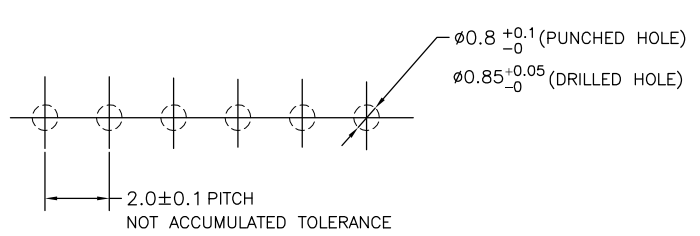

RECOMMENDABLE PCB LAYOUT
(PCB THK:0.8-1.6)

| TOLERANCES UNLESS OTHERWISE SPECIFIED: | |
|--|---------|
| 10 ≥ * | : ±0.2 |
| 30 ≥ * > 10 | : ±0.25 |
| 100 ≥ * > 30 | : ±0.3 |
| ANGLE | : ±3° |

| | | | | | | | | | |
|------------|------------|------------|------------|------------|------|----|------|------|------|
| | 7-292161-5 | 5-292161-5 | 3-292161-5 | 1-292161-5 | 15 | 28 | 31.8 | 25.2 | 31.0 |
| | 7- ↑ -4 | 5- ↑ -4 | 3- ↑ -4 | 1- ↑ -4 | 14 | 26 | 29.8 | 23.2 | 29.0 |
| | 7- -3 | 5- -3 | 3- -3 | 1- -3 | 13 | 24 | 27.8 | 21.2 | 27.0 |
| 9-292161-2 | 7- -2 | 5- -2 | 3- -2 | 1- -2 | 12 | 22 | 25.8 | 19.2 | 25.0 |
| 9- ↑ -1 | 7- -1 | 5- -1 | 3- -1 | 1- -1 | 11 | 20 | 23.8 | 17.2 | 23.0 |
| 9- = 0 | 7- -0 | 5- -0 | 3- -0 | 1- -0 | 10 | 18 | 21.8 | 15.2 | 21.0 |
| 8- -9 | 6- -9 | 4- -9 | 2- -9 | | 9 | 16 | 19.8 | 13.2 | 19.0 |
| 8- -8 | 6- -8 | 4- -8 | 2- -8 | | 8 | 14 | 17.8 | 11.2 | 17.0 |
| 8- -7 | 6- -7 | 4- -7 | 2- -7 | | 7 | 12 | 15.8 | 9.2 | 15.0 |
| 8- -6 | 6- -6 | 4- -6 | 2- -6 | | 6 | 10 | 13.8 | 7.2 | 13.0 |
| 8- -5 | 6- -5 | 4- -5 | 2- -5 | | 5 | 8 | 11.8 | 5.2 | 11.0 |
| 8- -4 | 6- -4 | 4- -4 | 2- -4 | | 4 | 6 | 9.8 | 3.2 | 9.0 |
| 8- ↓ -3 | 6- ↓ -3 | 4- ↓ -3 | 2- ↓ -3 | | 3 | 4 | 7.8 | - | 7.0 |
| 8-292161-2 | 6-292161-2 | 4-292161-2 | 2-292161-2 | 292161-2 | 2 | 2 | 5.8 | - | 5.0 |
| RED | BLACK | YELLOW | BLUE | NATURAL | Pos. | A | B | C | D |

| | | | | |
|--|--|------------------------|--|-----------------|
| THIS DRAWING IS A CONTROLLED DOCUMENT. | | DWN S.XU 31JAN03 | STE TE Connectivity | |
| | | CHK S.YAO 31JAN03 | | |
| | | APVD T. SASAKI 31JAN03 | NAME | |
| DIMENSIONS: mm | | PRODUCT SPEC 108-60016 | POST HEADER ASS'Y VERTICAL TYPE (AMP CT CONNECTOR 2mm PITCH) | |
| TOLERANCES UNLESS OTHERWISE SPECIFIED: | | APPLICATION SPEC | RESTRICTED TO | |
| MATERIAL SEE NOTE | | WEIGHT 0.000000 | SIZE A3 | CAGE CODE 00779 |
| | | CUSTOMER DRAWING | DRAWING NO C-292161 | SCALE 5:1 |
| | | | SHEET 1 OF 2 | REV P1 |

THIS DRAWING IS UNPUBLISHED.

RELEASED FOR PUBLICATION

© COPYRIGHT - By -

ALL RIGHTS RESERVED.

REVISIONS

| P | LTR | DESCRIPTION | DATE | DWN | APVD |
|---|-----|-------------|------|-----|------|
| - | - | SEE SHEET 1 | - | - | - |

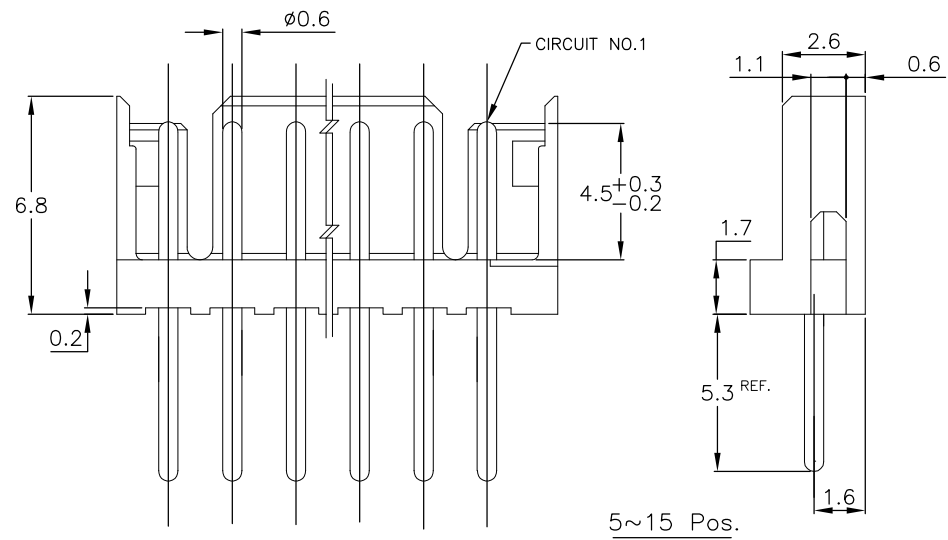
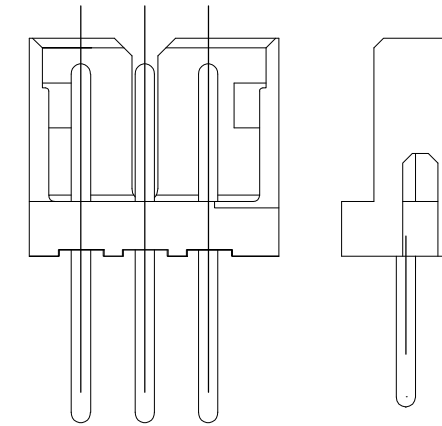
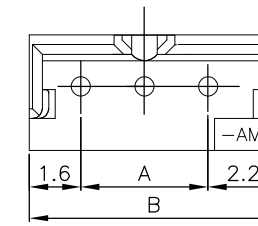
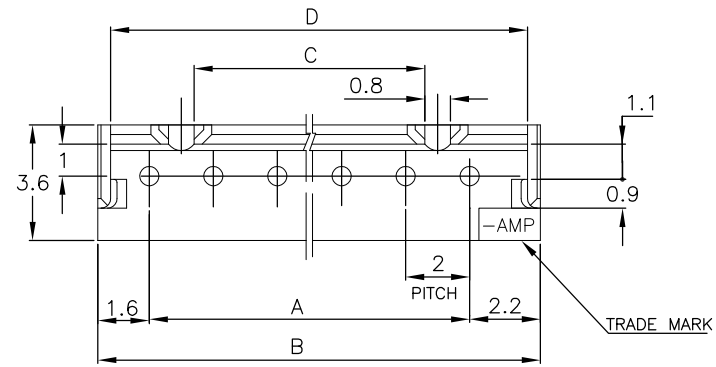

NOTES:

- 1.MATERIAL: HOUSING - NYLON 66 (UL94V-0)
POST - TIN BRASS
- 2.APPLICABLE RECEPTACLE P/N 173977

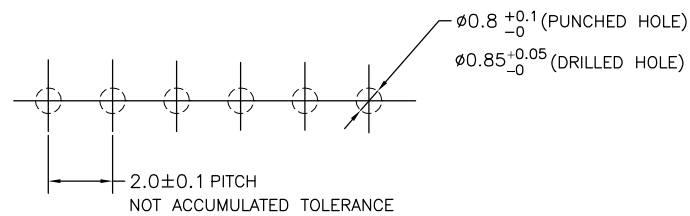

RECOMMENDABLE PCB LAYOUT (PCB THK:0.8-1.6)

TOLERANCES UNLESS OTHERWISE SPECIFIED:

| | | |
|--------------|---|-------|
| 10 ≥ * | : | ±0.2 |
| 30 ≥ * > 10 | : | ±0.25 |
| 100 ≥ * > 30 | : | ±0.3 |
| ANGLE | : | ±3° |

| | | | | | |
|------------|------|----|------|-----|------|
| 9-292161-7 | 7 | 12 | 15.8 | 9.2 | 15.0 |
| 9-292161-3 | 3 | 4 | 7.8 | - | 7.0 |
| NATURAL | Pos. | A | B | C | D |
| PART NO. | | | | | |

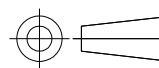
| | | | | | |
|---|--|------------------------|---|---------------|-----------|
| THIS DRAWING IS A CONTROLLED DOCUMENT. | | DWN S.XU 31JAN03 |  TE Connectivity POST HEADER ASS'Y VERTICAL TYPE (AMP CT CONNECTOR 2mm PITCH) | | |
| DIMENSIONS: mm | | CHK S.YAO 31JAN03 | | | |
| TOLERANCES UNLESS OTHERWISE SPECIFIED: | | APVD T. SASAKI 31JAN03 | | | |
|  | | NAME | | | |
| MATERIAL SEE NOTE | | FINISH SEE NOTE | PRODUCT SPEC 108-60016 | RESTRICTED TO | |
| | | | APPLICATION SPEC | SIZE | CAGE CODE |
| | | | WEIGHT 0.000000 | DRAWING NO | REV |
| | | | CUSTOMER DRAWING | A300779 | C-292161 |
| | | | SCALE 5:1 | SHEET 2 of 2 | P1 |