

Features

- **High Data Rates: 10Mbps At 5V Supply**
- **30/50ns (Max) Tx/Rx Propagation Delays; 6ns (Max) Skew**
- **Full Fail-safe (Open, Short, Terminated) Receivers**
- **Up to 256 Nodes on a Bus (1/8 unit load)**
- **Wide Supply Voltage 3V to 5.5V**
- **Low Quiescent Supply Current: 1.65 mA**
- **Bus-Pin Protection:**
 - ±15 kV HBM protection
 - ±15 kV IEC-ESD
- **Pb-Free**

Applications

- PROFIBUS® DP and FMS Networks
- SCSI “Fast 40” Drivers and Receivers
- Motor Controller/Position Encoder Systems
- Factory Automation
- Field Bus Networks
- Industrial/Process Control Networks

Pin Configuration (Top View)

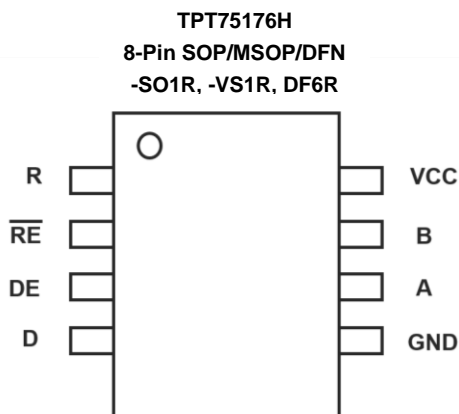

Description

3PEAK's TPT75176H is enhanced RS485 which exceeds standard TIA/EIA-485-A with ±15kV IEC-ESD Protected, 3V~5.5V powered, single transceiver for balanced communication. It also features the larger output voltage and higher data rate - up to 10Mbps - required by high speed PROFIBUS applications, and is offered in Industrial and Extended Industrial (-40°C to +125°C) temperature ranges.

This transceiver requires a 3V~5.5V tolerance supply, and delivers at least a 2.1V differential output voltage on 5V supply condition. This translates into better noise immunity (data integrity), longer reach, or the ability to drive up to three 120Ω terminations in “star” or other non-standard bus topologies, at the exceptional 10Mbps data rate.

Receiver (Rx) inputs feature a “Full Fail-Safe” design, which ensures a logic high Rx output if Rx inputs are floating, shorted, or terminated but undriven. Rx outputs feature high drive levels (typically >25mA @ V_{OL} = 1V) to ease the design of optically isolated interfaces.

The TPT75176H is available in an SOP8, MSOP8 and DFN3X3-8L package, and is characterized from -40°C to 125°C.

3PEAK and the 3PEAK logo are registered trademarks of 3PEAK INCORPORATED. All other trademarks are the property of their respective owners.

Loopback Test At 10Mbps/5V

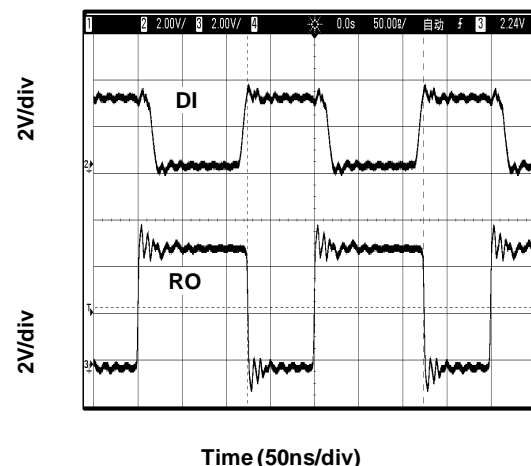

Revision History

Date	Revision	Notes
2019/2/22	Rev. Pre 0.1	Definition Version 0
2019/3/25	Rev. Pre 0.2	Update package information
2019/4/19	Rev. Pre 0.3	Update tape and reel information
2019/7/29	Rev. Pre 0.4	Update ESD level
2019/9/20	Rev. 0	Final version, update full temp data
2020/3/18	Rev. A	Update Receiver rise/fall time and add the note1 for Absolute Maximum Ratings
2020/10/31	Rev. B	Update VOH/VOL, VIH/VIL at 3.3V

Order Information

Model Name	Order Number	Package	Transport Media, Quantity	Marking Information
TPT75176H	TPT75176HL1-SO1R	8-Pin SOP	Tape and Reel, 4,000	T176H
TPT75176H	TPT75176H-VS1R	8-Pin MSOP	Tape and Reel, 3,000	176H
TPT75176H	TPT75176HL1-DF6R	8-Pin DFN	Tape and Reel, 4,000	176H

Functional Table

DRIVER PIN FUNCTIONS

INPUT	ENABLE	OUTPUTS		DESCRIPTION
D	DE	A	B	
NORMAL MODE				
H	H	H	L	Actively drives bus High
L	H	L	H	Actively drives bus Low
X	L	Z	Z	Driver disabled
X	OPEN	Z	Z	Driver disabled by default
OPEN	H	H	L	Actively drives bus High

RECEIVER PIN FUNCTIONS

DIFFERENTIAL INPUT	ENABLE	OUTPUT	DESCRIPTION
$V_{ID} = V_A - V_B$	/RE	R	
NORMAL MODE			
$V_{IT+} < V_{ID}$	L	H	Receive valid bus High
$V_{IT-} < V_{ID} < V_{IT+}$	L	?	Indeterminate bus state
$V_{ID} < V_{IT-}$	L	L	Receive valid bus Low
X	H	Z	Receiver disabled
X	OPEN	Z	Receiver disabled
Open, short, idle Bus	L	H	Indeterminate bus state

Absolute Maximum Ratings

V _{DD} to GND.....	-0.3V to +7V
Input Voltages D, DE, RE.....	-0.3V to (VCC + 0.3V)
Input/Output Voltages A, B.....	-15V to +15V
A, B (Transient Pulse Through 100Ω, Note 1).....	±100V
R.....	-0.3V to (VCC + 0.3V)
Short Circuit Duration A, B.....	Continuous
ESD Rating.....	See Specification Table

Note:

- (1) Support ±15V in receiver mode, and -8 ~+13V in driver mode
- (2) Stresses beyond the *Absolute Maximum Ratings* may cause permanent damage to the device. These are stress ratings only, which do not imply functional operation of the device at these or any other conditions beyond those indicated under *Recommended Operating Conditions*.

Recommended Operating Conditions

Supply Voltage.....	3V~5.5V
Temperature Range.....	-40°C to +125°C
Bus Pin Common Mode Voltage Range	-7V to +12V
Thermal Resistance, Θ_{JA} (Typical) 8-Pin SOP Package	152°C/W
8-Pin MSOP Package	200°C/W
Maximum Junction Temperature (Plastic Package)	+150°C
Maximum Storage Temperature Range	-65°C to +150°C

Note:

- (1) Tested according to TIA/EIA-485-A, Section 4.2.6 (±100V for 15μs at a 1% duty cycle).

Electrical Characteristics

Test Conditions: V_{CC} = 5V, Ta = -45 ~ +125°C (unless otherwise noted)

Parameter		Conditions	Min	Typ	Max	Units	
V _{OD}	Driver differential-output voltage magnitude	RL = 60 Ω with VA or VB from -7 to +12 V, VCC = 4.5V~5.5V	See Figure 1B	2.1	2.8	V	
		RL = 60 Ω with VA or VB from -7 to +12 V, VCC = 3.0~3.6V		1.5	2.0		
		RL = 54 Ω, VCC = 5V	See Figure 1A	2.1	2.8	V	
		RL = 54 Ω, VCC = 3V		1.5	1.9		
		RL = 100 Ω, VCC = 5V		2.1	3.5		
		RL = 100 Ω, VCC = 3V		1.5	2.3		
Δ V _{OD}	Change in magnitude of driver differential-output voltage	RL = 54 Ω, CL=50 pF, VCC = 5V	See Figure 1A	-50	1	50	mV
V _{OC(SS)}	Steady-stage common-mode output voltage	Center of two 27 Ω load resistors	See Figure 1A	1	V _{CC} /2	3	V
ΔV _{OC}	Change in differential driver common-mode output voltage ^[1]			50	mV		
V _{OC(PP)}	Peak-to-peak driver common-mode output voltage ^[1]			500			
C _{OD}	Differential output capacitance ^[1]			8		pF	
V _{IT+}	Positive-going receiver differential-input voltage threshold	V _A or V _B from -7 to +12 V		-90	-40	mV	
V _{IT-}	Negative-going receiver differential-input voltage threshold	V _A or V _B from -7 to +12 V	-220	-155		mV	
V _{HYS}	Receiver differential-input voltage threshold hysteresis (V _{IT+} - V _{IT-}) ^[1]			70		mV	
V _{IH}	Logic Input High Voltage	D, DE, \overline{RE}	2			V	
V _{IL}	Logic Input Low Voltage	D, DE, \overline{RE}			0.8	V	
V _{OH}	Receiver high-level output voltage	I _{OH} = -8 mA, V _{CC} = 4.5V to 5.5V	3	4.5		V	
		I _{OH} = -8 mA, V _{CC} = 3.0V to 3.6V	2.45	2.65		V	
V _{OL}	Receiver low-level output voltage	I _{OL} = 8 mA, V _{CC} = 4.5V to 5.5V			0.4	V	
		I _{OL} = 8 mA, V _{CC} = 3.0V to 3.6V			0.5	V	
I _I	Driver input, driver enable and	D, DE, \overline{RE}	-5		5	μA	
I _{OZ}	Receiver high-Z output current	V _O = 0 V or V _{CC} , /RE at V _{CC}	-1		1	μA	
I _{OS}	Driver short-circuit output current	IOS with V _A or V _B from -7 to +12 V	-250	120	250	mA	
		Bus pin A,B short current			150	mA	
I _{IN}	Bus input current(driver disabled)	V _{CC} = 4.5 to 5.5 V or V _{CC} = 0 V, DE at 0 V	VI= 12 V		120	uA	
			VI= -7 V	-110			
I _{CC}	Supply current(quietcent)	Driver and receiver enabled	DE = V _{CC} , /RE = GND, No LOAD		1.9	2.2	mA
		Driver enabled, receiver disabled	DE = V _{CC} , /RE = V _{CC} , No LOAD		1.8	2.2	
		Driver disabled, receiver enabled	DE = GND, /RE = GND, No LOAD		1.7	2.0	
		Driver and receiver disabled	DE = GND, /RE = V _{CC} , D= V _{CC} No LOAD		1.65	2.0	

Switching Characteristics

PARAMETER		CONDITIONS		MIN	TYP	MAX	UNITS
DRIVER							
f_{MAX}	Maximum Data Rate ^[1]	$V_{OD} \geq \pm 1.5V$, $R_L = 54\Omega$, $C_L = 100pF$ (Figure 4)				10	Mbps
t_r, t_f	Driver differential-output rise and fall times ^[1]	$R_L = 54\Omega$, $C_L = 50pF$	See Figure 2		8		ns
t_{PHL}, t_{PLH}	Driver propagation delay				21	30	
$t_{SK(P)}$	Driver pulse skew, $ t_{PHL} - t_{PLH} $				3	6	
t_{PHZ}, t_{PLZ}	Driver disable time		See Figure 3		30	50	ns
t_{PZH}, t_{PZL}	Driver enable time	Receiver enabled			20	45	
	Driver enable time	Receiver disabled			30	50	ns
RECEIVER							
t_r, t_f	Receiver output rise and fall times ^[1]	$C_L = 15pF$	See Figure 5		14		ns
t_{PHL}, t_{PLH}	Receiver propagation delay time				35	50	
$t_{SK(P)}$	Receiver pulse skew, $ t_{PHL} - t_{PLH} $				10	15	
t_{PHZ}, t_{PLZ}	Receiver disable time			30	60	ns	
t_{PZH}, t_{PZL}	Receiver enable time	Driver enabled			20	30	ns
	Receiver enable time	Driver disabled			25	40	ns
ESD							
Human Body Model, per ANSI/ESDA/JEDEC JS-001 / ANSI/ESD STM5.5.1		RS-485 Pins (A, B)			±15		kV
		All Other Pins			±4		kV
CDM, per ANSI/ESDA/JEDEC JS-002		RS-485			±1.5		kV
IEC-61000-4-2, IEC-Contact ESD, Bus Pins		RS-485 Pins (A, B)			±15		kV

Note

[1] Parameter is provided by lab bench test and design simulation

Test Circuits and Waveforms

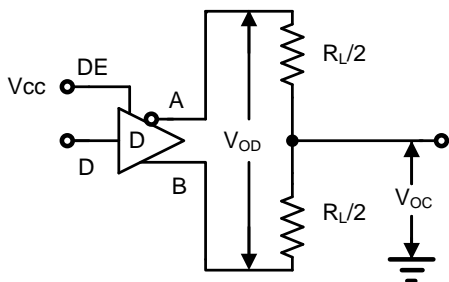

Figure 1A. VOD and VOC

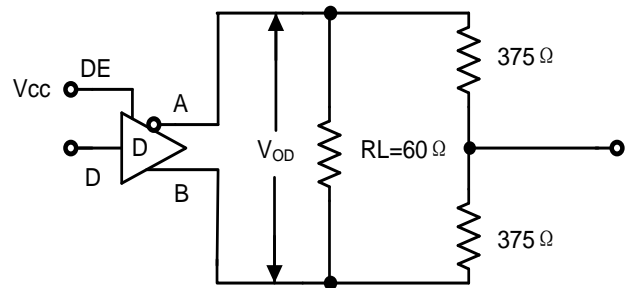

Figure 1B. VOD with Common Mode Load

Figure 1. DC Driver Test Circuits

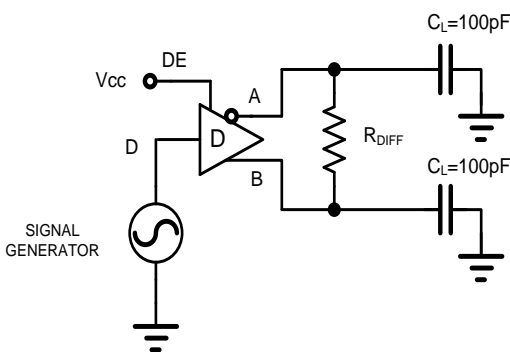

Figure 2A. Test Circuit

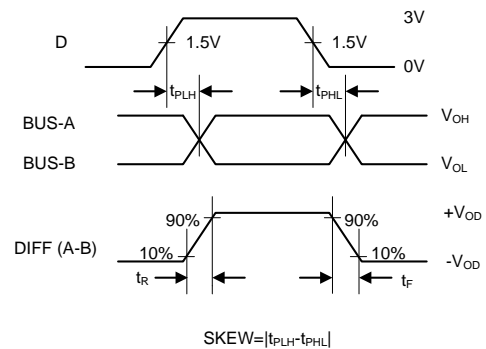

Figure 2B. Measurement Points

Figure 2. Driver Propagation Delay and Differential Transition Times

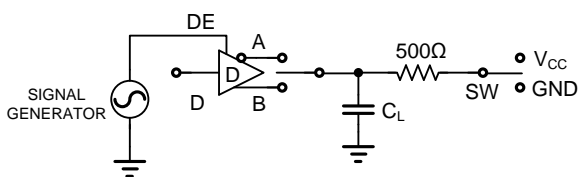

Figure 3A. Test Circuit

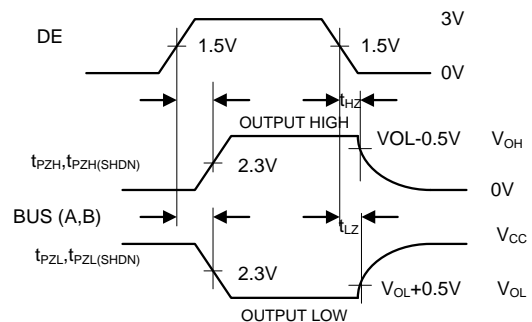

Figure 3B. Measurement Points

Figure 3. Driver Enable and Disable Times

PARAMETER	OUTPUT	RE	DI	SW	CL (pF)
tPHZ	A/B	X	1/0	GND	15
tPLZ	A/B	X	0/1	VCC	15
tPZH	A/B	0	1/0	GND	100
tPZL	A/B	0	0/1	VCC	100
tPZH(SHDN)	A/B	1	1/0	GND	100
tPZL(SHDN)	A/B	1	0/1	VCC	100

Test Circuits and Waveforms (continue)

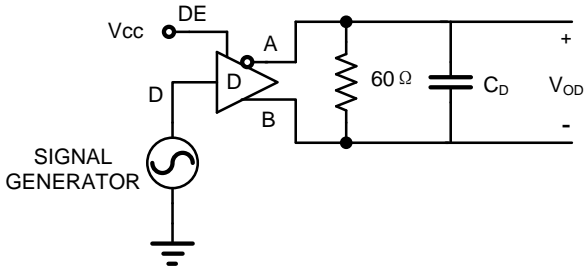

Figure 4A. Test Circuit

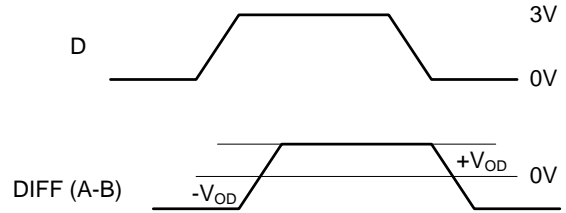

Figure 4B. Measurement Points

Figure 4. Driver Data rate

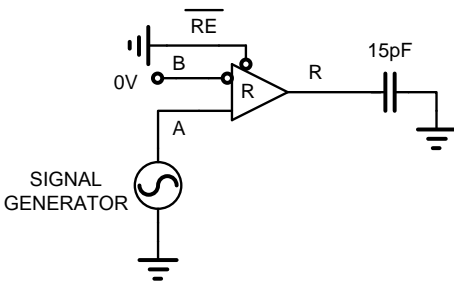

Figure 5A. Test Circuit

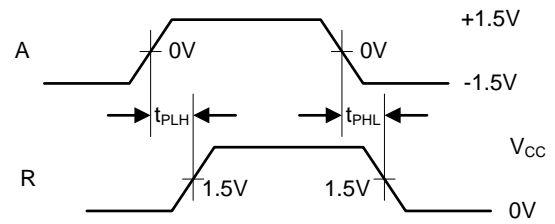

Figure 5B. Measurement Points

Figure 5. Receiver Propagation Delay and Data rate

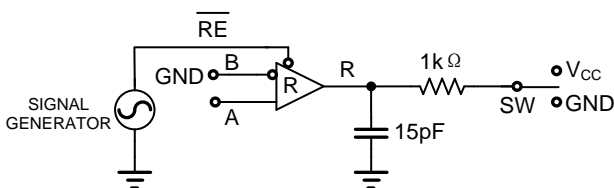

Figure 6A. Test Circuit

PARAMETER	DE	A	SW
tPHZ	1	+1.5V	GND
tPLZ	1	-1.5V	VCC
tPZH	1	+1.5V	GND
tPZL	1	-1.5V	VCC
tPZH(SHDN)	0	+1.5V	GND
tPZL(SHDN)	0	-1.5V	VCC

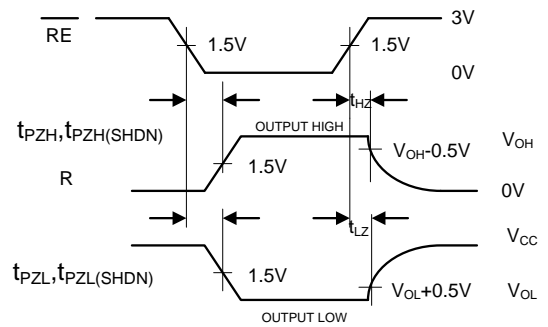

Figure 6B. Measurement Points

Figure 6. Receiver Enable and Disable Times

Detailed Description

High Data Rate

RS-485/RS-422 are intended for network lengths up to 4000', but the maximum system data rate decreases as the transmission length increases. Devices operating at 10Mbps are limited to lengths less than 100'.

Twisted pair is the cable of choice for RS-485/RS-422 networks. Twisted pair cables tend to pick up noise and other electromagnetically induced voltages as common mode signals, which are effectively rejected by the differential receiver in this IC. Proper termination is imperative to minimize reflections. In point-to-point, or point-to-multipoint (single driver on bus) networks, the main cable should be terminated in its characteristic impedance (typically 120Ω) at the end farthest from the driver. In multi-receiver applications, stubs connecting receivers to the main cable should be kept as short as possible. Multipoint (multi-driver) systems require that the main cable be terminated in its characteristic impedance at both ends. Stubs connecting a transceiver to the main cable should be kept as short as possible.

The TPT75176H may also be used at slower data rates over longer cables, but there are some limitations. The Rx is optimized for high speed operation, so its output may glitch if the Rx input differential transition times are too slow. Keeping the transition times below 500ns, which equates to the Tx driving a 1000' (305m) CAT 5 cable, yields excellent performance over the full operating temperature range. For below test waveform, the transmitter was driven at 10Mbps and/or with 100' (31m) CAT 5 cable, the transmitters were loaded with an RS-485 receiver in parallel with 54Ω.

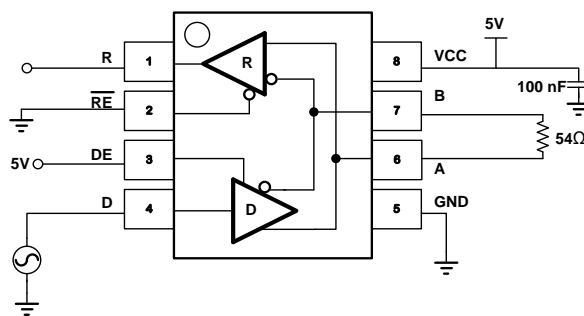
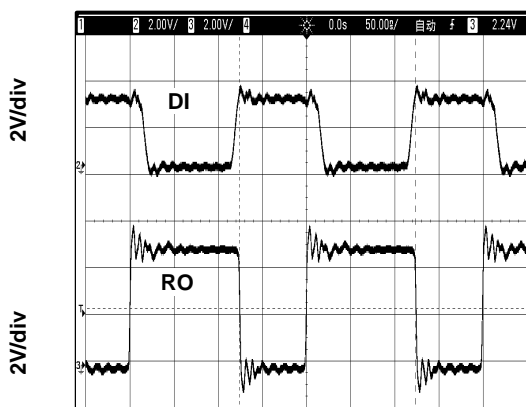

Figure 7. Loopback Test Circuit



Time (50ns/div)

Figure 8. Loopback Test at 10Mbps/5V



Time (100ns/div)

Figure 9. Loopback Test at 6Mbps/3V

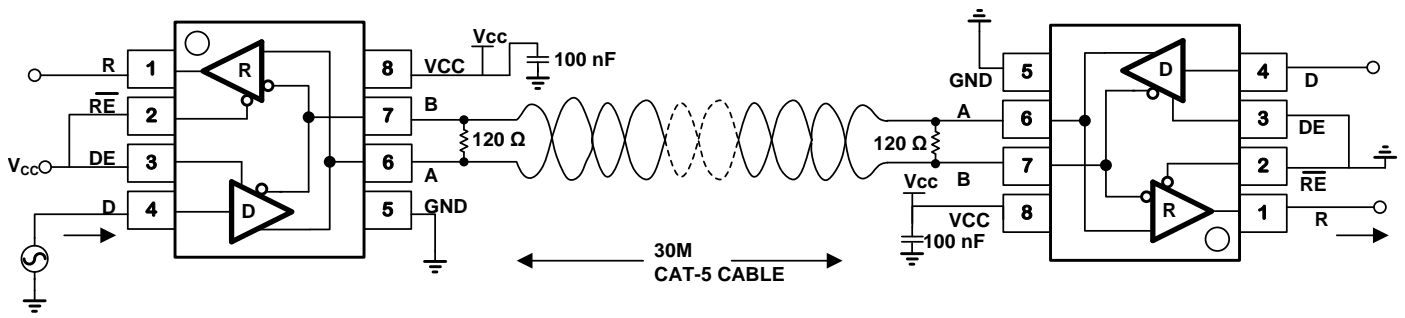
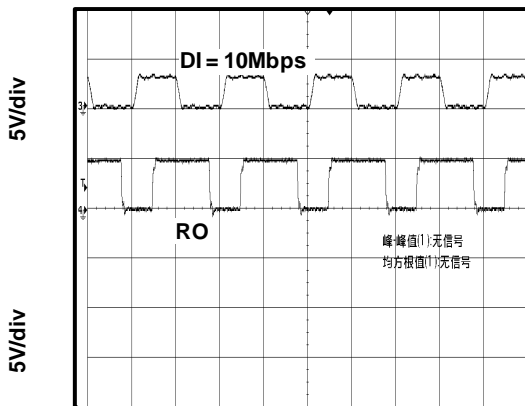
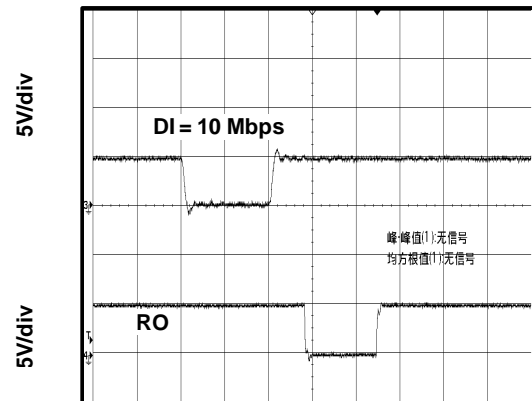

Figure 10. 10Mbps Data Rate With 30M CAT5 Cable Test Circuit



Time (100ns/div)

Figure 11. 5V Driver and Receiver Five Pulse Waveforms Driving 100 Feet (30 Meters)



Time (100ns/div)

Figure 12. 5V Driver and Receiver Single Pulse Waveforms Driving 100 Feet (30 Meters)

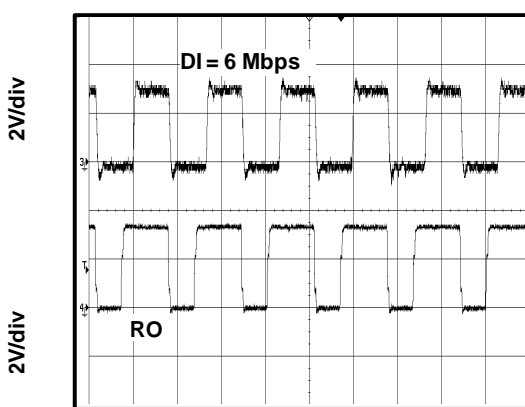

Time (200ns/div)

Figure 13. 3.3V Driver and Receiver Five Pulse Waveforms Driving 100 Feet (30 Meters)

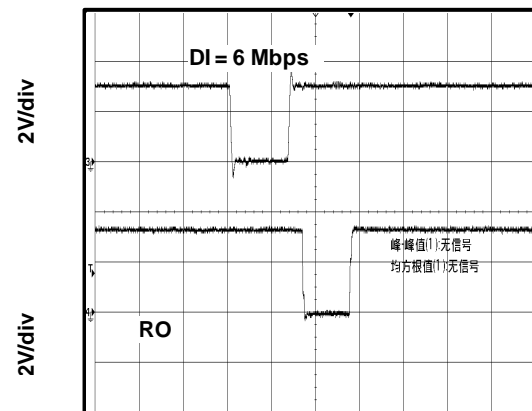

Time (200ns/div)

Figure 14. 3.3V Driver and Receiver Single Pulse Waveforms Driving 100 Feet (30 Meters)

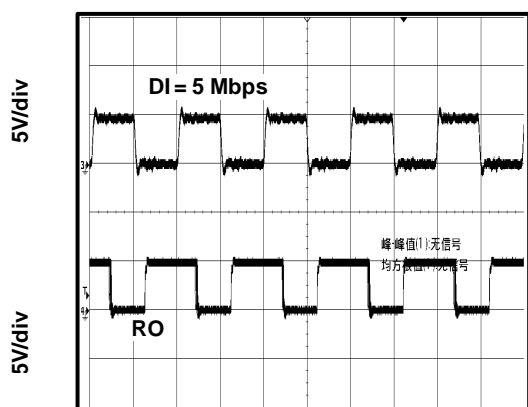

Time (200ns/div)

Figure 15. 5V Driver and Receiver Five Pulse Waveforms Driving 100 Feet (30 Meters)

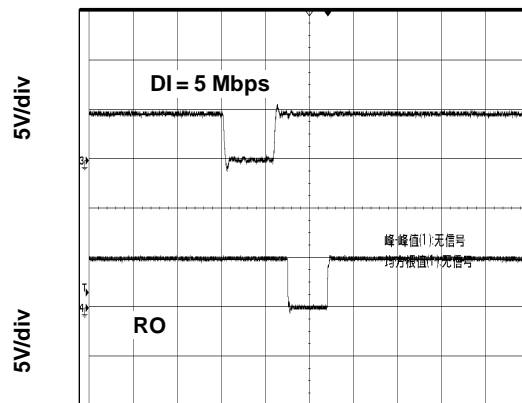

Time (200ns/div)

Figure 16. 5V Driver and Receiver Single Pulse Waveforms Driving 100 Feet (30 Meters)

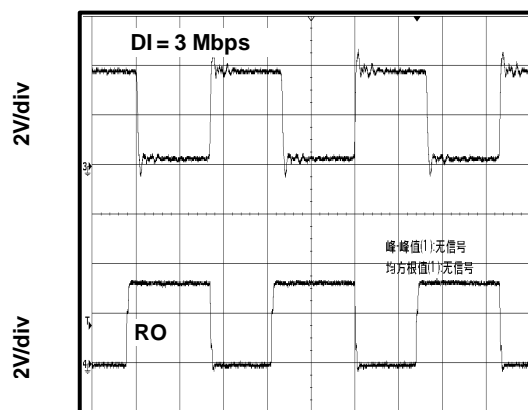

Time (200ns/div)

Figure 17. 3.3V Driver and Receiver Four Pulse Waveforms Driving 100 Feet (30 Meters)

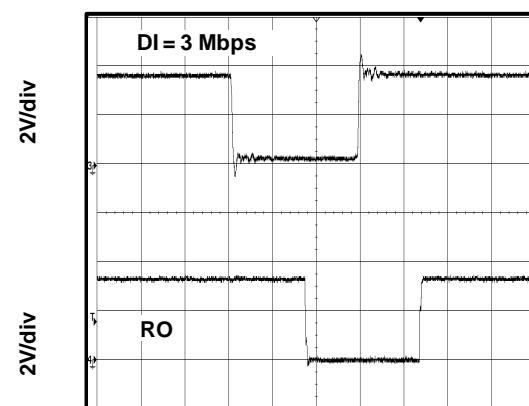

Time (200ns/div)

Figure 18. 5V Driver and Receiver Single Pulse Waveforms Driving 100 Feet (30 Meters)

Full Fail-Safe

All the receivers include a “full fail-safe” function that guarantees a high level receiver output if the receiver inputs are unconnected (floating), shorted together, or connected to a terminated bus with all the transmitters disabled. Receivers easily meet the data rates supported by the corresponding driver, and all receiver outputs are three-stable via the active low RE input.

Hot Plug Function

When a piece of equipment powers up, there is a period of time where the processor or ASIC driving the RS-485 control lines (DE, RE) is unable to ensure that the RS-485 Tx and Rx outputs are kept disabled. If the equipment is connected to the bus, a driver activating prematurely during power-up may crash the bus. To avoid this scenario, the TPT75176H devices incorporate a “Hot Plug”

function. Circuitry monitoring VCC ensures that, during power-up and power-down, the Tx and Rx outputs remain disabled, regardless of the state of DE and RE, if VCC is less than ~2.5V. This gives the processor/ASIC a chance to stabilize and drive the RS-485 control lines to the proper states.

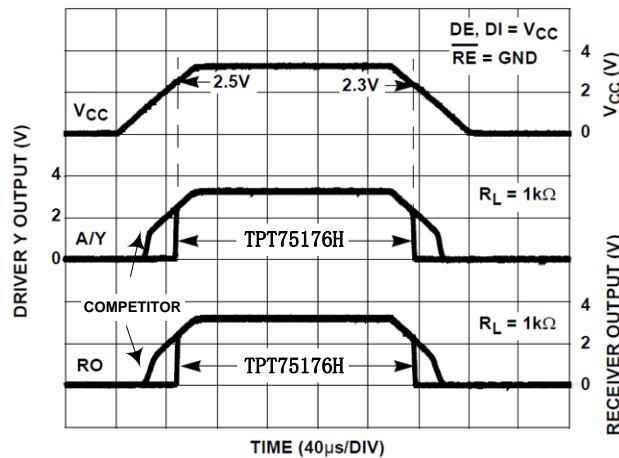

FIGURE 19. Hot Plug Performance (TPT75176H) vs Competitor Without Hot Plug Circuitry

Transient Protection

The bus terminals of the TPT75176H transceiver family possess on-chip ESD protection against ±15 kV HBM. The International Electrotechnical Commission (IEC) ESD test is far more severe than the HBM ESD test. The 50% higher charge capacitance, CS, and 78% lower discharge resistance, RD of the IEC model produce significantly higher discharge currents than the HBM model. As stated in the IEC 61000-4-2 standard, contact discharge is the preferred transient protection test method. Although IEC air-gap testing is less repeatable than contact testing, air discharge protection levels are inferred from the contact discharge test results.

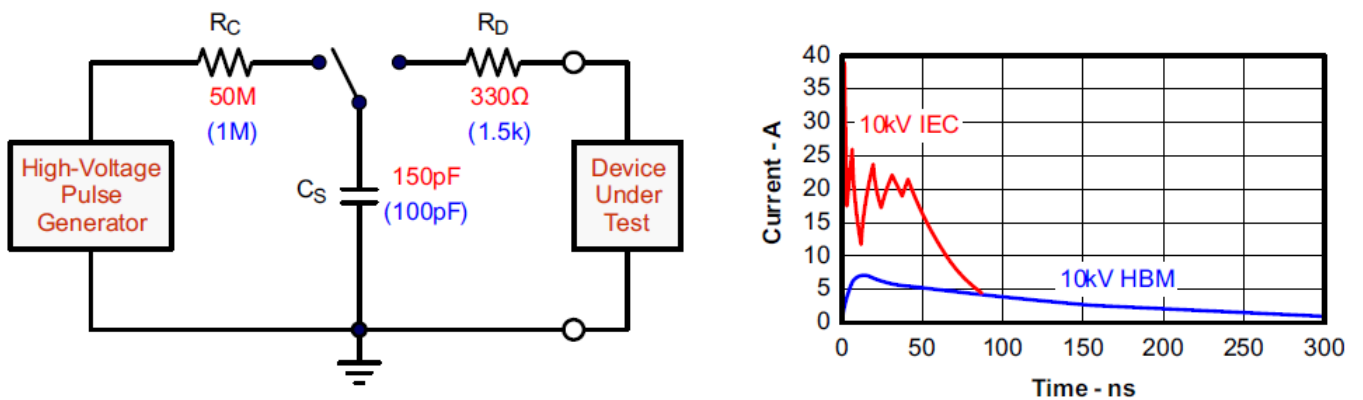

Figure 20. HBM and IEC-ESD Models and Currents in Comparison (HBM Values in Parenthesis)

The on-chip implementation of IEC ESD protection significantly increases the robustness of equipment. Common discharge events occur because of human contact with connectors and cables. Designers may choose to implement protection against longer duration transients, typically referred to as surge transients. Figure 9 suggests two circuit designs providing protection against short and long duration surge transients, in addition to ESD and Electrical Fast Transients (EFT) transients. Table 1 lists the bill of materials for the external protection devices.

EFTs are generally caused by relay-contact bounce or the interruption of inductive loads. Surge transients often result from lightning strikes (direct strike or an indirect strike which induce voltages and currents), or the switching of power systems, including load

changes and short circuits switching. These transients are often encountered in industrial environments, such as factory automation and power-grid systems. Figure 10 compares the pulse-power of the EFT and surge transients with the power caused by an IEC ESD transient. In the diagram on the left of Figure 10, the tiny blue blip in the bottom left corner represents the power of a 10-kV ESD transient, which already dwarfs against the significantly higher EFT power spike, and certainly dwarfs against the 500-V surge transient. This type of transient power is well representative of factory environments in industrial and process automation. The diagram on the right of Figure 10 compares the enormous power of a 6-kV surge transient, most likely occurring in e-metering applications of power generating and power grid systems, with the aforementioned 500-V surge transient.

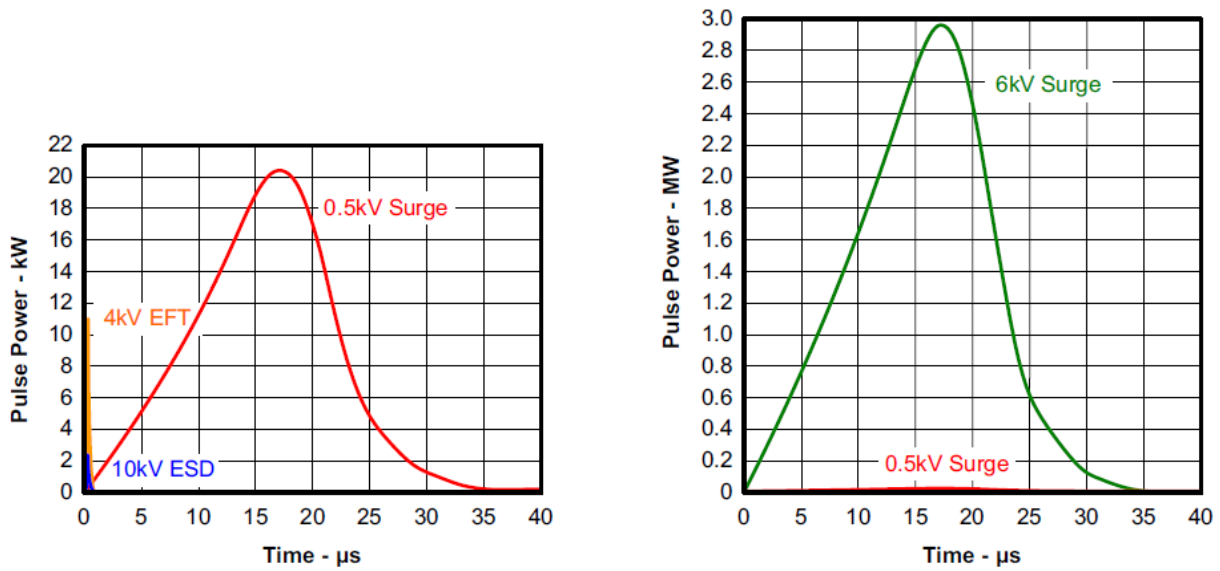

Figure 21. Power Comparison of ESD, EFT, and Surge Transients

In the case of surge transients, high-energy content is signified by long pulse duration and slow decaying pulse Power The electrical energy of a transient that is dumped into the internal protection cells of the transceiver is converted into thermal energy. This thermal energy heats the protection cells and literally destroys them, thus destroying the transceiver. Figure 11 shows the large differences in transient energies for single ESD, EFT, and surge transients as well as for an EFT pulse train, commonly applied during compliance testing.

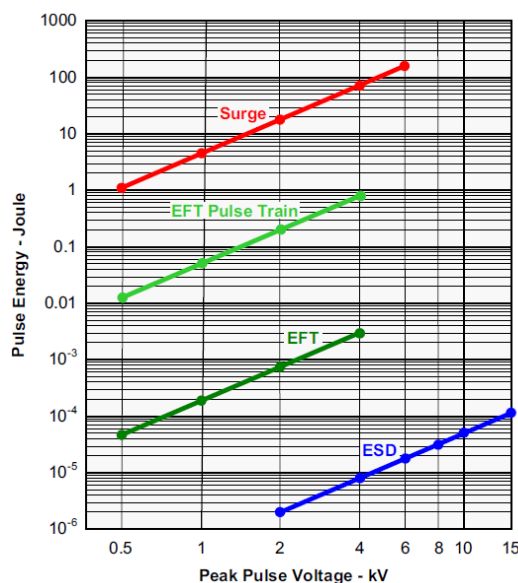

Figure 22. Comparison of Transient Energies

Table 1. Bill of Materials

Device	Function	Order Number	Manufacturer
485	5-V, 10Mbps RS-485 Transceiver	TPT75176H	3PEAK
R1, R2	10-Ω, Pulse-Proof Thick-Film Resistor	CRCW0603010RJNEAHP	Vishay
TVS	Bidirectional 400-W Transient Suppressor	CDSOT23-SM712	Bourns
TBU1, TBU2	Bidirectional	TBU-CA-065-200-WH	Bourns
MOV1, MOV2	200mA Transient Blocking Unit 200-V, Metal-Oxide Varistor	MOV-10D201K	Bourns

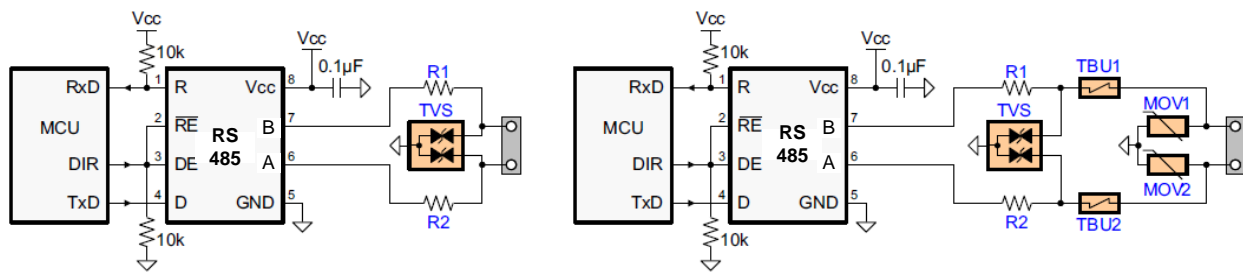
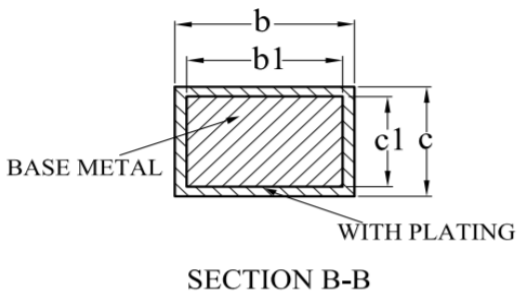
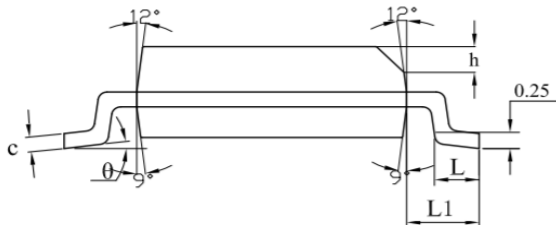
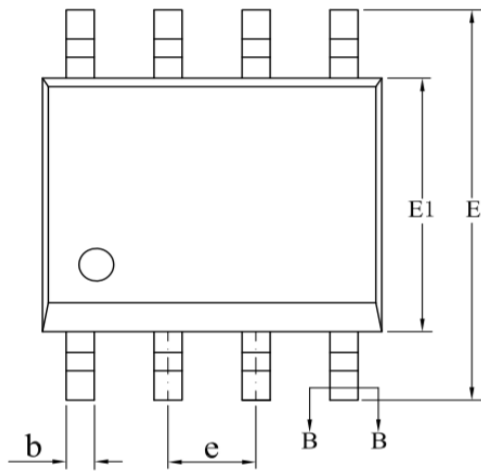
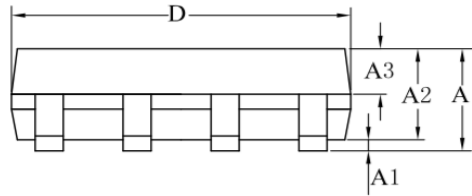

Figure 23. Transient Protections against ESD, EFT, and Surge Transients

The left circuit shown in Figure 12 provides surge protection of $\geq 500\text{-V}$ transients, while the right protection circuits can withstand surge transients of 5 kV

Package Outline Dimensions

SO1R (SOP8)



SYMBOL	MILLIMETER		
	MIN	NOM	MAX
A	—	—	1.75
A1	0.10	—	0.225
A2	1.30	1.40	1.50
A3	0.60	0.65	0.70
b	0.39	—	0.47
b1	0.38	0.41	0.44
c	0.20	—	0.24
c1	0.19	0.20	0.21
D	4.80	4.90	5.00
E	5.80	6.00	6.20
E1	3.80	3.90	4.00
e	1.27BSC		
h	0.25	—	0.50
L	0.50	—	0.80
L1	1.05REF		
θ	0	—	8°

Package Outline Dimensions

VS1R (MSOP8)

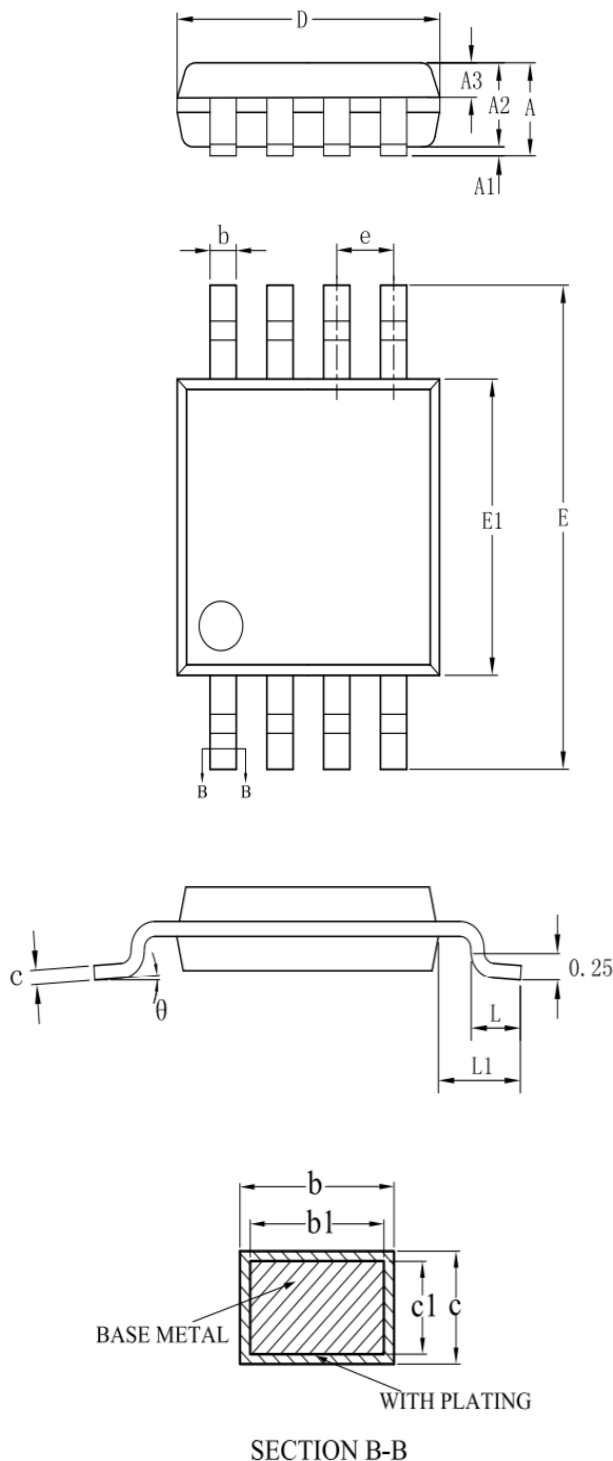

SYMBOL	MILLIMETER		
	MIN	NOM	MAX
A	—	—	1.10
A1	0.05	—	0.15
A2	0.75	0.85	0.95
A3	0.30	0.35	0.40
b	0.28	—	0.36
b1	0.27	0.30	0.33
c	0.15	—	0.19
c1	0.14	0.15	0.16
D	2.90	3.00	3.10
E	4.70	4.90	5.10
E1	2.90	3.00	3.10
e	0.65BSC		
L	0.40	—	0.70
L1	0.95REF		
θ	0	—	8°

Package Outline Dimensions

DF6R (DFN3X3-8L)

DFNWB3×3-8L-F (P0.65T0.75/0.85) PACKAGE OUTLINE DIMENSIONS

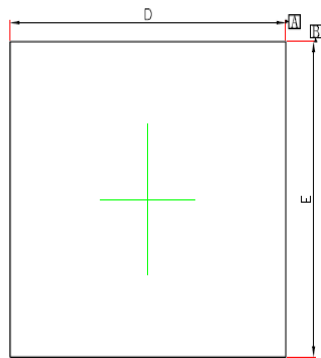

TOP VIEW

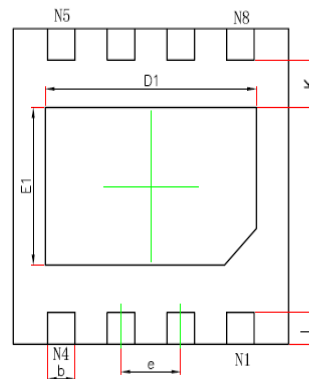

BOTTOM VIEW

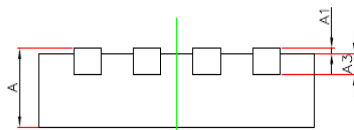

SIDE VIEW

Symbol	Dimensions In Millimeters		Dimensions In Inches	
	Min.	NOM.	Min.	NOM.
A	0.700/0.800	0.800/0.900	0.028/0.031	0.031/0.035
A1	0.000	0.050	0.000	0.002
A3	0.203REF.		0.008REF.	
D	3.000BSC.		0.118BSC.	
E	3.000BSC.		0.118BSC.	
D1	2.200	2.400	0.087	0.094
E1	1.400	1.600	0.055	0.063
k	0.250MIN.		0.010MIN.	
b	0.250	0.350	0.010	0.014
e	0.650TYP.		0.026TYP.	
L	0.224	0.376	0.009	0.015