DisplayPort to TMDS Translator

FEATURES

- DisplayPort Physical Layer Input Port to TMDS Physical Layer Output Port
- Integrated TMDS level translator with Receiver Equalization
- Supports Data Rates up to 2.5Gbps
- Integrated I²C Logic Block for DVI/HDMI Connector Recognition
- Integrated Active I²C Buffer
- Enhanced ESD: 10KV on all pins
- Enhanced Commercial Temperature Range: 0°C to 85°C
- 48 Pin 7 × 7 QFN Package

APPLICATIONS

- Personal Computer Market
 - DP/TMDS Dongle
 - Desktop PC
 - Notebook PC
 - Docking Station
 - Standalone Video Card

DESCRIPTION

The SN75DP139 is a Dual-Mode DisplayPort input to Transition-Minimized Differential Signaling (TMDS) output. The TMDS output has a built in level translator supporting Digital Video Interface (DVI) 1.0 and High Definition Multimedia Interface (HDMI) 1.3 standards. The SN75DP139 is specified up to a maximum data rate of 2.5Gbps, supporting resolutions greater than 1920x1200 or HDTV 12 bit color depth at 1080p (progressive scan).

An integrated Active I²C buffer isolates the capacitive loading of the source system from that of the sink and interconnecting cable. This isolation improves overall signal integrity of the system and allows for considerable design margin within the source system for DVI / HDMI compliance testing.

A logic block was designed into the SN75DP139 in order to assist with TMDS connector identification. Through the use of the I²C_EN pin, this logic block can be enabled to indicate the translated port is an HDMI port; therefore legally supporting HDMI content.



Please be aware that an important notice concerning availability, standard warranty, and use in critical applications of Texas Instruments semiconductor products and disclaimers thereto appears at the end of this data sheet.



These devices have limited built-in ESD protection. The leads should be shorted together or the device placed in conductive foam during storage or handling to prevent electrostatic damage to the MOS gates.

TYPICAL APPLICATION

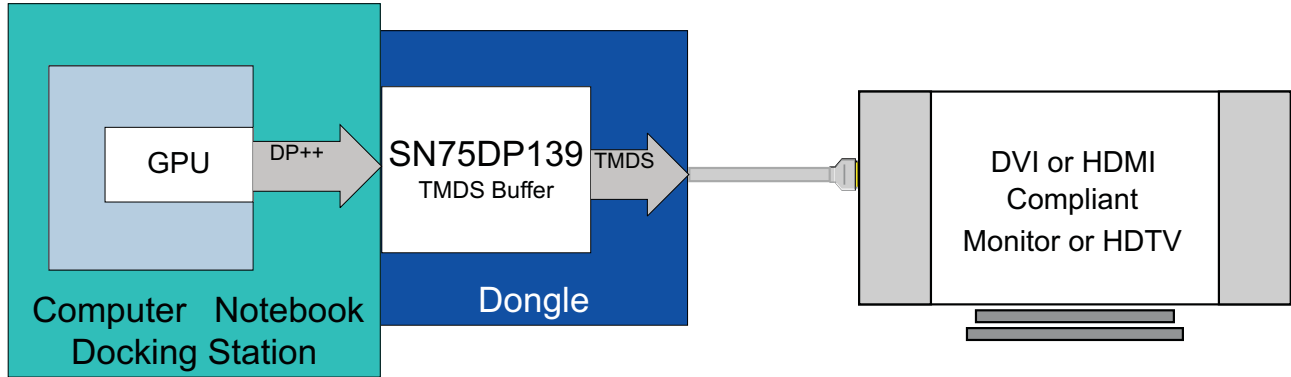

GPU - Graphics Processing Unit
 DP++ - Dual-Mode DisplayPort
 TMDS - Transition-Minimized Differential Signaling
 DVI - Digital Visual Interface

HDMI - High Definition Multimedia Interface

GPU	Graphics Processing Unit
DP++	Dual-Mode DisplayPort
TMDS	Transition-Minimized Differential Signaling
DVI	Digital Visual Interface
HDMI	High Definition Multimedia Interface

DATA FLOW BLOCK DIAGRAM

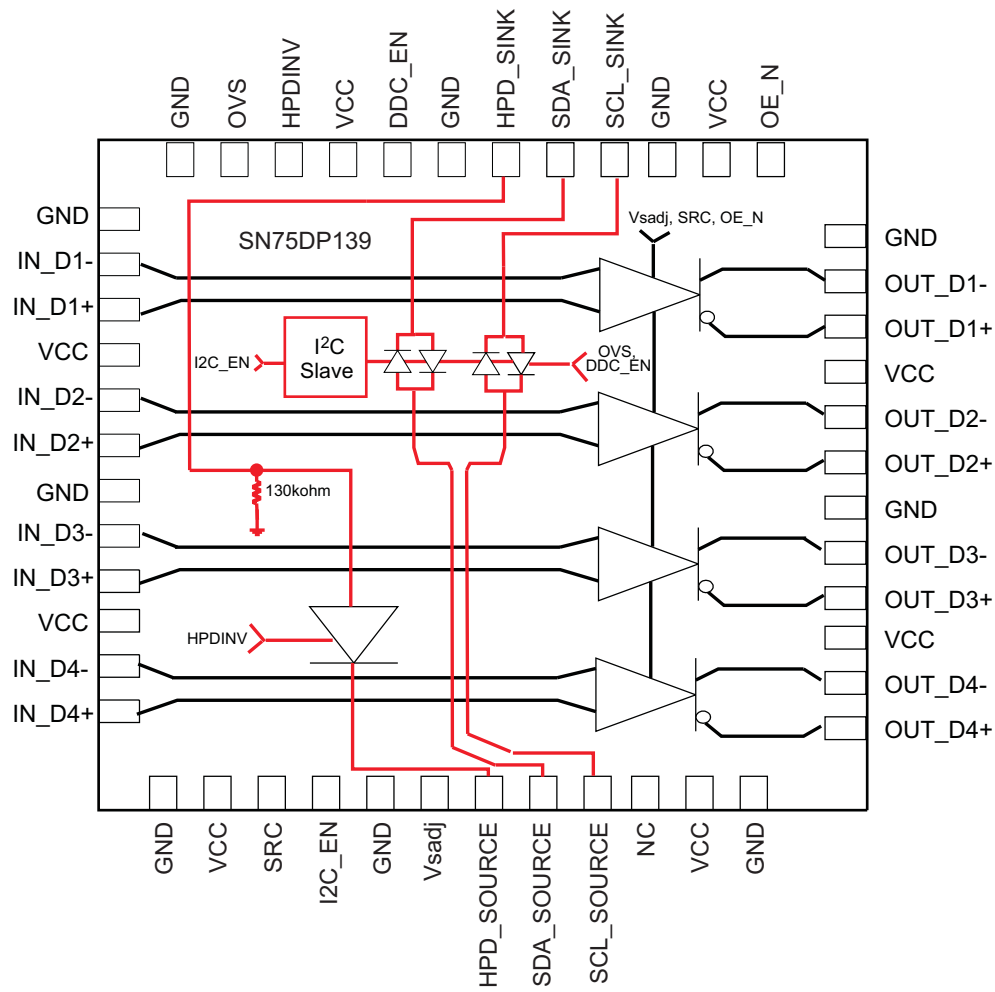

DEVICE INFORMATION

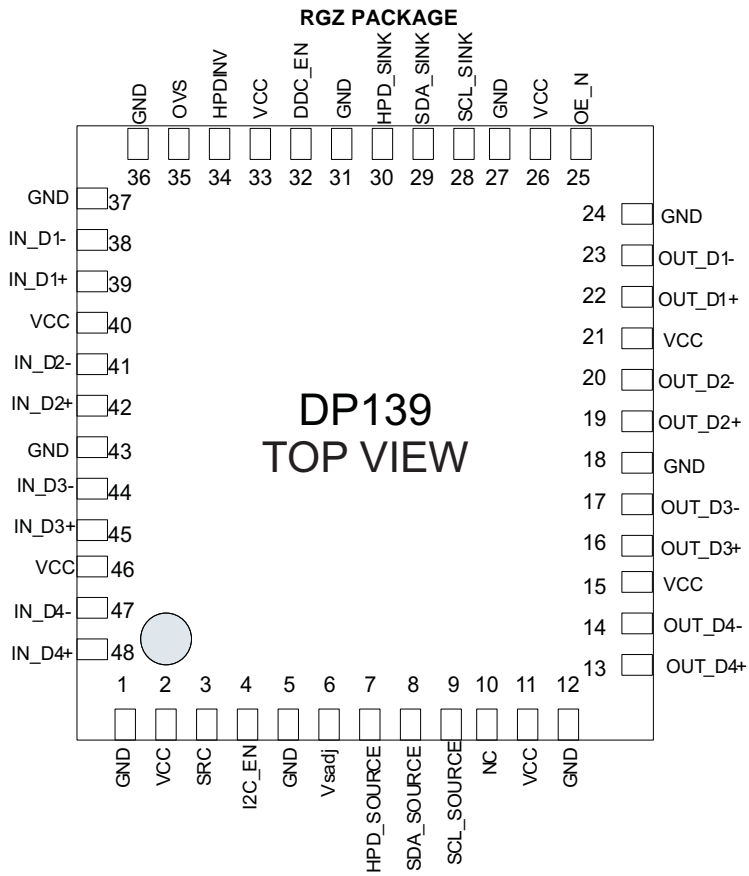

PIN FUNCTIONS

PIN		I/O	DESCRIPTION
SIGNAL	NO.		
MAIN LINK INPUT PINS			
IN_D1	38, 39	I	DisplayPort Main Link Channel 0 Differential Input
IN_D2	41, 42	I	DisplayPort Main Link Channel 1 Differential Input
IN_D3	44, 45	I	DisplayPort Main Link Channel 2 Differential Input
IN_D4	47, 48	I	DisplayPort Main Link Channel 3 Differential Input
MAIN LINK PORT B OUTPUT PINS			
OUT_D1	23, 22	O	TMDS Data 2 Differential Output
OUT_D2	20, 19	O	TMDS Data 1 Differential Output
OUT_D3	17, 16	O	TMDS Data 0 Differential Output
OUT_D4	14, 13	O	TMDS Data Clock Differential Output
HOT PLUG DETECT PINS			
HPD_SOURCE	7	O	Hot Plug Detect Output
HPD_SINK	30	I	Hot Plug Detect Input
AUXILIARY DATA PINS			
SDA_SOURCE, SCL_SOURCE	8, 9	I/O	Source Side Bidirectional DisplayPort Auxiliary Data Line
SDA_SINK, SCL_SINK	29, 28	I/O	TMDS Port Bidirectional DDC Data Lines
CONTROL PINS			
OE_N	25	I	Output Enable and power saving function for High Speed Differential level shifter path.
NC	10		No Connect
OVS	35	I	DDC I2C buffer offset select
DDC_EN	32	I	Enables or Disables the DDC I2C buffer
HPDINV	34	I	HPD_SOURCE Logic and Level Select
VSadj	6	I	TMDS Compliant Voltage Swing Control
SRC	3	I	TMDS outputs rise and fall time select
I2C_EN	4	I	Internal I ² C register enable, used for HDMI / DVI connector differentiation
SUPPLY AND GROUND PINS			
VCC	2, 11, 15, 21, 26, 33, 40, 46		3.3V Supply
GND	1, 5, 12, 18, 24, 27, 31, 36, 37, 43		Ground

Input/Output Equivalent Circuits

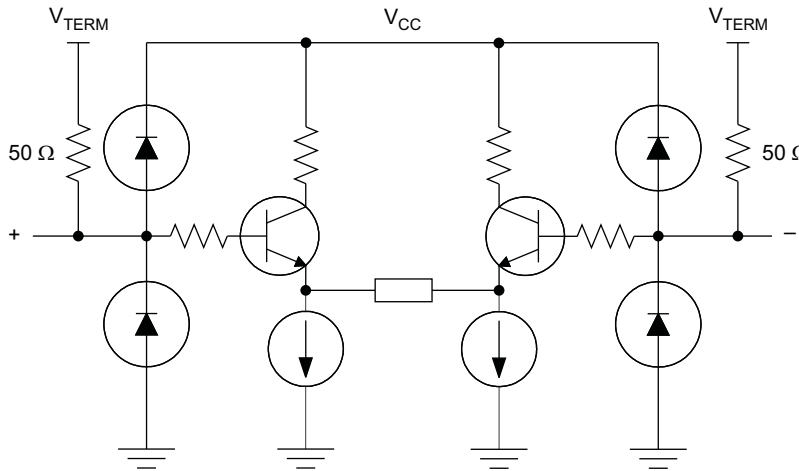

Figure 1. DisplayPort Input Stage

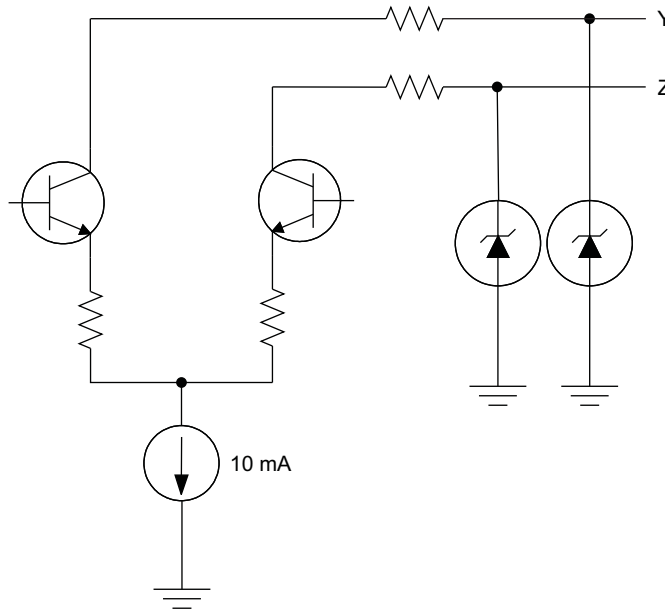

Figure 2. TMD5 Output Stage

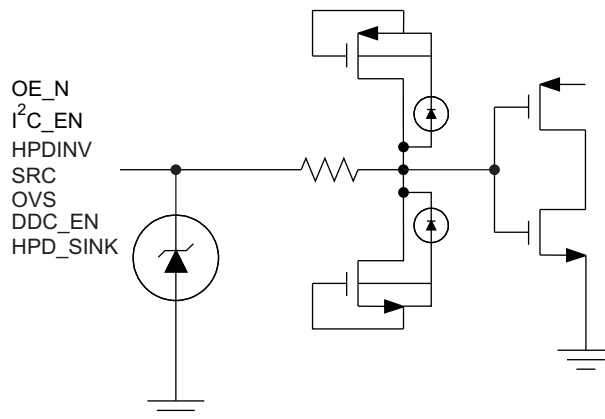

Figure 3. HPD and Control Input Stage

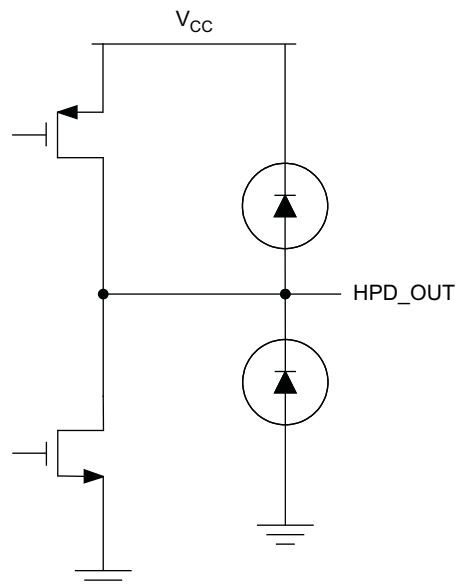

Figure 4. HPD Output Stage

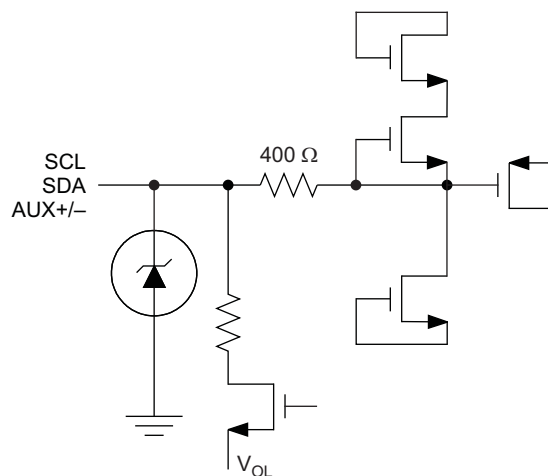

Figure 5. I²C Input and Output Stage

Table 1. Control Pin Lookup Table

SIGNAL	LEVEL ⁽¹⁾	STATE	DESCRIPTION
OE_N	H	Power Saving Mode	Main Link is disabled. IN_Dx termination = 50 Ω with common mode voltage set to 0V. OUT_Dx outputs = high impedance
	L	Normal Mode	IN_Dx termination = 50 Ω OUT_Dx outputs = active
I ² C_EN	H	HDMI	The Internal I2C register is active and readable when the TMDS port is selected indicating that the connector being used is HDMI. This mode selects the fastest rise and fall time for the TMDS differential output signals
	L	DVI	The Internal I2C register is disabled and not readable when the TMDS port is selected indicating that the connector being used is DVI. This mode selects a slower rise and fall time for the TMDS differential output signals See DVI Application Section .
VSadj	4.02 kΩ ±5%	Output Voltage Swing Control	Driver output voltage swing precision control to aid with system compliance
HPDINV	H	HPD Inversion	HPD_SOURCE VOH =0.9V (typical) and HPD logic is inverted
	L	HPD non-inversion	HPD_SOURCE VOH =3.2V (typical) and HPD logic is non-inverted
SRC	H	Edge Rate: Slowest	SRC helps to slow down the rise and fall time. SRC =High adds ~60ps to the rise and fall time of the TMDS differential output signals in addition to the I2C_EN pin selection
	L	Edge Rate: Slow	SRC helps to slow down the rise and fall time. SRC =Low adds ~30ps to the rise and fall time of the TMDS differential output signals in addition to the I2C_EN pin selection
	Hi-Z	Edge Rate	Leaving the SRC pin High Z, will keep the default rise and fall time of the TMDS differential output signals as selected by the I2C_EN pin. It is recommended that an external resistor-divider (less than 100 kΩ) is used so that voltage on this pin = VCC/2, if Hi-Z logic level is intended on this pin.
OVS	H	Offset 1	DDC source side VOL and VIL offset range 1
	L	Offset 2	DDC source side VOL and VIL offset range 2
	Hi-Z	Offset 3	DDC source side VOL and VIL offset range 3 It is recommended that an external resistor-divider (less than 100 kΩ) is used so that voltage on this pin = VCC/2, if Hi-Z logic level is intended on this pin.
DDC_EN	H	DDC Buffer enabled	DDC Buffer is enabled
	L	DDC buffer disabled	DDC Buffer is disabled

(1) (H) Logic High; (L) Logic Low; (Z) High Z

ORDERING INFORMATION⁽¹⁾

PART NUMBER	PART MARKING	PACKAGE
SN75DP139RGZR	DP139	48-pin QFN Reel (large)
SN75DP139RGZT	DP139	48-pin QFN Reel (small)

(1) For the most current package and ordering information, see the Package Option Addendum at the end of this document, or see the TI web site at www.ti.com.

ABSOLUTE MAXIMUM RATINGS

over operating free-air temperature range (unless otherwise noted) ⁽¹⁾

		VALUE	UNIT
Supply voltage range ⁽²⁾	VCC	–0.3 to 3.6	V
Voltage range	Main Link Input (IN_Dx) differential voltage	1.56	V
	TMDS Outputs (OUT_Dx)	–0.3 to 4	V
	HPD I/O (HPD_SOURCE, HPD_SINK)	–0.3 to 5.5	V
	Auxiliary I/O (SCL_SOURCE, SDA_SOURCE, SCL_SINK, SDA_SINK)	–0.3 to 5.5	V
	Control I/O (OE_N, DDC_EN, SRC, OVS, HPDINV)	–0.3 to 5.5	V
Electrostatic discharge	Human body model ⁽³⁾	±10000	V
	Charged-device model ⁽⁴⁾	±1500	V
	Machine model ⁽⁵⁾	±200	V
Continuous power dissipation		See Dissipation Rating Table	

(1) Stresses beyond those listed under absolute maximum ratings may cause permanent damage to the device. These are stress ratings only and functional operation of the device at these or any conditions beyond those indicated under recommended operating conditions is not implied. Exposure to absolute-maximum-rated conditions for extended periods may affect device reliability.

(2) All voltage values, except differential voltages, are with respect to network ground terminal.

(3) Tested in accordance with JEDEC Standard 22, Test Method A114-B

(4) Tested in accordance with JEDEC Standard 22, Test Method C101-A

(5) Tested in accordance with JEDEC Standard 22, Test Method A115-A

DISSIPATION RATINGS

PACKAGE	PCB JEDEC STANDARD	T _A ≤ 25°C	DERATING FACTOR ⁽¹⁾ ABOVE T _A = 25°C	T _A = 85°C POWER RATING
48-pin QFN (RGZ)	Low-K	1426.8 mW	14.28 mW/°C	570 mW
	High-K	3125 mW	31.25 mW/°C	1250 mW

(1) This is the inverse of the junction-to-ambient thermal resistance when board-mounted and with no air flow.

THERMAL CHARACTERISTICS

over operating free-air temperature range (unless otherwise noted)

PARAMETER		TEST CONDITIONS	MIN	TYP	MAX ⁽¹⁾	UNIT
R _{θJB}	Junction-to-board thermal resistance			9		°C/W
R _{θJC}	Junction-to-case thermal resistance			22		°C/W
P _{D1}	Device power dissipation ⁽²⁾	HDMI Mode: OE_N = 0V, DDC_EN = 5V, V _{CC} = 3.6V, ML: VID_PP = 1200mV, 2.5Gbps TMDS pattern AUX: V _I = 3.3V, 100 kHz PRBS HPD: HPD_SINK = 5V, I2C_EN = 5V, SRC = Hi-Z		270+146 ⁽²⁾	396+146 ⁽²⁾	mW
P _{D2}	Device power dissipation ⁽²⁾	DVI Mode: OE_N = 0V, DDC_EN = 5V, V _{CC} = 3.6V, ML: VID_PP = 1200mV, 2.5Gbps TMDS pattern AUX: V _I = 3.3V, 100 kHz PRBS HPD: HPD_SINK = 5V, I2C_EN = 0V, SRC = Hi-Z		214+146 ⁽²⁾	306+146 ⁽²⁾	mW
P _{SD1}	Device power dissipation under low power with HPDINV = LOW	OE_N = 5V, DDC_EN = 0V, HPDINV = 0V, HPD_SINK = 0V		18	54	μW
P _{SD2}	Device power dissipation under low power with HPDINV = HIGH	OE_N = 5V, DDC_EN = 0V, HPDINV = 5V		1.7	3	mW
P _{SD3}	Device power dissipation under low power with DDC enabled with HPDINV = HIGH	OE_N = 5V, DDC_EN = 5V, HPDINV = 5V		16.5	29	mW
P _{SD4}	Device power dissipation under low power with DDC enabled with HPDINV = LOW	OE_N = 5V, DDC_EN = 5V, HPDINV = 0V		15	26	mW

(1) The maximum rating is simulated under 3.6V V_{CC} unless otherwise noted.

(2) Power dissipation is the sum of the power consumption from the VCC pins, plus the 146 mW of power from the AVCC (HDMI/DVI Receiver Termination Supply).

RECOMMENDED OPERATING CONDITIONS

over operating free-air temperature range (unless otherwise noted)

		MIN	NOM	MAX	UNIT
V _{CC}	Supply Voltage	3	3.3	3.6	V
T _A	Operating free-air temperature	0		85	°C
MAIN LINK DIFFERENTIAL INPUT PINS					
V _{ID_PP}	Peak-to-peak AC input differential voltage	0.15		1.2	V
d _R	Data rate	0.25		2.5	Gbps
t _{rise fall time}	Input Signal Rise and Fall time (20%-80%)	75			ps
V _{PRE}	Pre-emphasis on the Input Signal at IN_Dx pins	0	0	0	db
TMDS DIFFERENTIAL OUTPUT PINS					
AV _{CC}	TMDS output termination voltage	3	3.3	3.6	V
d _R	Data rate	0.25		2.5	Gbps
R _T	Termination resistance	45	50	55	Ω
R _{Vsadj}	TMDS output swing voltage bias resistor ⁽¹⁾	3.65	4.02		kΩ
AUXILIARY AND I2C PINS					
V _I	Input voltage	0		5.5	V
d _{R(I2C)}	I ² C data rate			100	kHz

(1) R_{Vsadj} resistor controls the SN75DP139 Driver output voltage swing and thus helps in meeting system compliance. It is recommended that R_{Vsadj} resistor should be above the MIN value as indicated in the RECOMMENDED OPERATING CONDITIONS table, however for NOM and MAX value, [Figure 24](#) could be used as reference. It is important to note that system level losses, AV_{CC} and R_T variation affect R_{Vsadj} resistor selection. Worse case variation on system level losses, AV_{CC}, R_T could make R_{Vsadj} resistor value of 4.02 kΩ ±5% result in non-compliant TMDS output voltage swing. In such cases [Figure 24](#) could be used as reference.

RECOMMENDED OPERATING CONDITIONS (continued)

over operating free-air temperature range (unless otherwise noted)

		MIN	NOM	MAX	UNIT
HPD_SINK, HPDINV, OE_N, DDC_EN, I2C_EN					
V _{IH}	High-level input voltage	2		5.5	V
V _{IL}	Low-level input voltage	0		0.8	V
SRC, OVS					
V _{IH_SRC_OVS}	High-level input voltage	3		5.5	V
V _{IL_SRC_OVS}	Low-level input voltage	0		0.5	V

DEVICE POWER

The SN75DP139 is designed to operate off of one supply voltage VCC.

The SN75DP139 offers features to enable or disable different functionality based on the status of the output enable (OE_N) and DDC Enable (DDC_EN) inputs.

- OE_N affects only the High Speed Differential channels (Main Link/TMDS link). OE_N has no influence on the HPD_SINK input, HPD_SOURCE output, or the DDC buffer.
- DDC_EN affects only the DDC channel. The DDC_EN should never change state during the I2C operation. Disabling DDC_EN during a bus operation will hang the bus, while enabling the DDC_EN during bus traffic will corrupt the I2C bus operation. DDC_EN should only be toggled while the bus is idle.
- TMDS output edge rate control has impact on the SN75DP139 Active power. See [Figure 20](#). TMDS output edge rate can be controlled by SRC pin. Slower output Edge Rate Setting helps in reducing the Active power consumption.

HPD_SINK	HPDINV	OE_N	DDC_EN	IN_Dx	OUT_Dx	DDC	HPD_SOURCE	MODE
Input = H or L	L	L	L	50 Ω termination active	Enabled	High-impedance	Output = non inverted, follows HPD_SINK	Active
Input = H or L	L	L	H	50 Ω termination active	Enabled	enabled	Output = non inverted, follows HPD_SINK	Active
Input = H or L	L	H	L	50 Ω termination active: Terminations connected to common Mode Voltage = 0V.	High-impedance	High-impedance	Output = non inverted, follows HPD_SINK	Low Power
Input = H or L	L	H	H	50 Ω termination active: Terminations connected to common Mode Voltage = 0V.	High-impedance	enabled	Output = non inverted, follows HPD_SINK	Low Power with DDC channel enabled
Input = H or L	H	L	L	50 Ω termination active	Enabled	High-impedance	Output = inverted, follows HPD_SINK	Active
Input = H or L	H	L	H	50 Ω termination active	Enabled	enabled	Output = inverted, follows HPD_SINK	Active
Input = H or L	H	H	L	50 Ω termination active: Terminations connected to common Mode Voltage = 0V.	High-impedance	High-impedance	Output = inverted, follows HPD_SINK	Low Power
Input = H or L	H	H	H	50 Ω termination active: Terminations connected to common Mode Voltage = 0V.	High-impedance	enabled	Output = inverted, follows HPD_SINK	Low Power with DDC channel enabled

L = LOW, H = HIGH

ELECTRICAL CHARACTERISTICS

over operating free-air temperature range (unless otherwise noted)

PARAMETER		TEST CONDITIONS	MIN	TYP	MAX	UNIT
I _{CC1}	Supply current (HDMI Mode)	HDMI Mode: OE_N = 0V, DDC_EN = 5V, V _{CC} = 3.6V, ML: VID_PP = 1200mV, 2.5Gbps TMDS pattern AUX: V _I = 3.3V, 100 kHz PRBS HPD: HPD_SINK = 5V, I2C_EN = 5V, SRC = Hi-Z		82	110	mA
I _{CC2}	Supply Current (DVI Mode)	DVI Mode: OE_N = 0V, DDC_EN = 5V, V _{CC} = 3.6V, ML: VID_PP = 1200mV, 2.5Gbps TMDS pattern AUX: V _I = 3.3V, 100 kHz PRBS HPD: HPD_SINK= 5V, I2C_EN = 0V, SRC = Hi-Z		65	85	mA
I _{SD1}	Shutdown current with HPDINV = LOW	OE_N = 5V, DDC_EN = 0V, HPDINV = 0V, HPD_SINK = 0V		5.5	15	μA
I _{SD2}	Shutdown current with HPDINV = HIGH	OE_N = 5V, DDC_EN = 0V, HPDINV = 5V		0.5	0.8	mA
I _{SD3}	Shutdown current with DDC enabled with HPDINV = HIGH	OE_N = 5V, DDC_EN = 5V, HPDINV = 5V		5	8	mA
I _{SD4}	Shutdown current with DDC enabled with HPDINV = LOW	OE_N = 5V, DDC_EN = 5V, HPDINV = 0V		4.5	7.2	mA

Hot Plug Detect

The SN75DP139 has a built in level shifter for the HPD outputs. The output voltage level of the HPD pin is defined by the voltage level of the VCC pin. The HPD input or HPD_SINK side has 130kohm of pull down resistor integrated.

The logic of the HPD_SOURCE output always follows the logic state of the HPD_SINK input based on the HPDINV pin logic, regardless of whether the device is in Active or Low Power Mode

ELECTRICAL CHARACTERISTICS

over recommended operating conditions (unless otherwise noted)

PARAMETER		TEST CONDITIONS	MIN	TYP	MAX	UNIT
V _{OH3.3}	High-level output voltage	I _{OH} = -100 μA, V _{CC} = 3.3 V ±10%, HPDINV = LOW	2.8		3.6	V
V _{OH1.1}	High-level output voltage	I _{OH} = -100 μA, V _{CC} = 3.3 V ±10%, HPDINV = HIGH	0.8		1.1	V
V _{OL}	Low-level output voltage	I _{OH} = 100 μA	0		0.1	V
I _{IH}	High-level input current	V _{IH} = 2.0 V, V _{CC} = 3.6 V	-30		30	μA
I _{IL}	Low-level input current	V _{IL} = 0.8 V, V _{CC} = 3.6 V	-30		30	μA
R _{INTHPD}	Input pull down on HPD_SINK (HPD Input)		110	130	160	kΩ

SWITCHING CHARACTERISTICS

over recommended operating conditions (unless otherwise noted)

PARAMETER		TEST CONDITIONS	MIN	TYP	MAX	UNIT
t _{PD(HPD)}	Propagation delay	V _{CC} = 3.6 V		2	30	ns

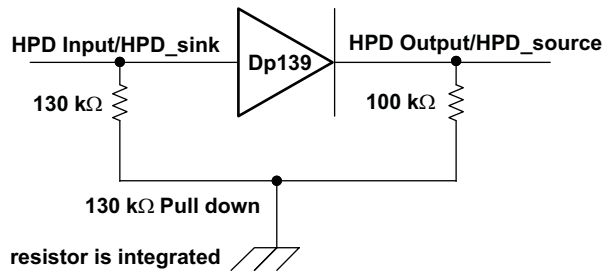

Figure 6. HPD Test Circuit (HPDINV = LOW)

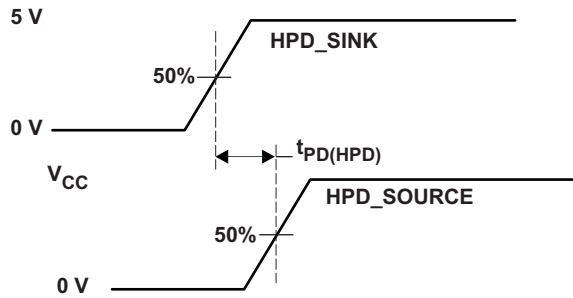

Figure 8. HPD Timing Diagram (HPDINV = LOW)

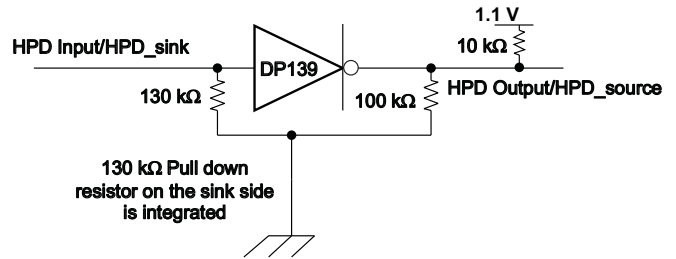

Figure 7. HPD Test Circuit (VOH = 1.1), HPDINV = HIGH

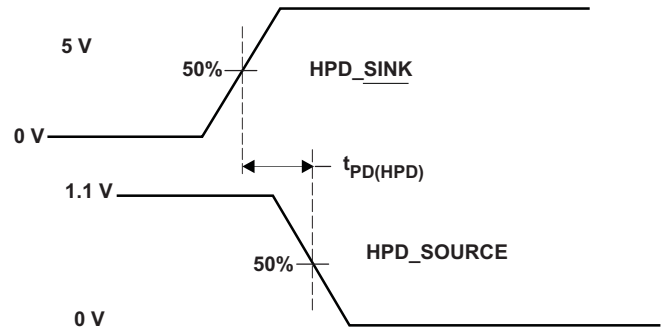

Figure 9. HPD Timing Diagram (HPDINV = HIGH)

AUX / I²C pins

The SN75DP139 utilizes an active I²C repeater. The repeater is designed to isolate the parasitic effects of the system in order to aid with system level compliance.

In addition to the I²C repeater, the SN75DP139 also supports the connector detection I²C register. This register is enabled via the I²C_EN pin. When active an internal memory register is readable via the AUX_I²C I/O. The functionality of this register block is described in the APPLICATION INFORMATION section.

ELECTRICAL CHARACTERISTICS

over recommended operating conditions (unless otherwise noted)

PARAMETER			TEST CONDITIONS	MIN	TYP	MAX	UNIT
I _L	Low input current		V _{CC} = 3.6 V, V _I = 0 V	-10		10	μA
I _{ikg(AUX)}	Input leakage current	AUX_I ² C pins (SCL_SOURCE, SDA_SOURCE)	V _{CC} = 3.6V, V _I = 3.6 V	-10		10	μA
C _{IO(AUX)}	Input/Output capacitance	AUX_I ² C pins (SCL_SOURCE, SDA_SOURCE)	DC bias = 1.65 V, AC = 2.1Vp-p, f = 100 kHz			15	pF
V _{IH(AUX)}	High-level input voltage	AUX_I ² C pins (SCL_SOURCE, SDA_SOURCE)		1.6		5.5	V
V _{IL1(AUX)}	Low-level input voltage	AUX_I ² C pins (SCL_SOURCE, SDA_SOURCE)	OVS = HIGH	-0.2		0.4	V
V _{OL1(AUX)}	Low-level output voltage	AUX_I ² C pins (SCL_SOURCE, SDA_SOURCE)	I _O = 3 mA, OVS = HIGH	0.6		0.7	V
V _{IL2(AUX)}	Low-level input voltage	AUX_I ² C pins (SCL_SOURCE, SDA_SOURCE)	OVS = Hi-Z	-0.2		0.4	V
V _{OL2(AUX)}	Low-level output voltage	AUX_I ² C pins (SCL_SOURCE, SDA_SOURCE)	I _O = 3 mA, OVS = Hi-Z	0.5		0.6	V
V _{IL3(AUX)}	Low-level input voltage	AUX_I ² C pins (SCL_SOURCE, SDA_SOURCE)	OVS = Low	-0.2		0.3	V
V _{OL3(AUX)}	Low-level output voltage	AUX_I ² C pins (SCL_SOURCE, SDA_SOURCE)	I _O = 3 mA, OVS = Low	0.4		0.5	V
I _{ikg(I2C)}	Input leakage current	I ² C SDA/SCL pins (SCL_SINK, SDA_SINK)	V _{CC} = 3.6 V, V _I = 4.95 V	-10		10	μA
C _{IO(I2C)}	Input/Output capacitance	I ² C SDA/SCL pins (SCL_SINK, SDA_SINK)	DC bias = 2.5 V, AC = 3.5Vp-p, f = 100 kHz			15	pF
V _{IH(I2C)}	High-level input voltage	I ² C SDA/SCL pins (SCL_SINK, SDA_SINK)		2.1		5.5	V
V _{IL(I2C)}	Low-level input voltage	I ² C SDA/SCL pins (SCL_SINK, SDA_SINK)		-0.2		1.5	V
V _{OL(I2C)}	Low-level output voltage	I ² C SDA/SCL pins (SCL_SINK, SDA_SINK)	I _O = 3mA			0.2	V

SWITCHING CHARACTERISTICS

over recommended operating conditions (unless otherwise noted)

PARAMETER	TEST CONDITIONS	MIN	TYP	MAX	UNIT
t_{PLH1}	Propagation delay time, low to high	Source to Sink	204	600	ns
t_{PHL1}	Propagation delay time, high to low	Source to Sink	35	200	ns
t_{PLH2}	Propagation delay time, low to high	Sink to Source	80	251	ns
t_{PHL2}	Propagation delay time, high to low	Sink to Source	35	200	ns
t_{f1}	Output signal fall time	Sink Side	20	72	ns
t_{f2}	Output signal fall time	Source Side	20	72	ns
f_{SCL}	SCL clock frequency for internal register	Source Side		100	kHz
$t_{W(L)}$	Clock LOW period for I ² C register	Source Side	4.7		μ s
$t_{W(H)}$	Clock HIGH period for internal register	Source Side	4.0		μ s
t_{SU1}	Internal register setup time, SDA to SCL	Source Side	250		ns
$t_{h(1)}$	Internal register hold time, SCL to SDA	Source Side	0		μ s
$T_{(buf)}$	Internal register bus free time between STOP and START	Source Side	4.7		μ s
$t_{su(2)}$	Internal register setup time, SCL to START	Source Side	4.7		μ s
$t_{h(2)}$	Internal register hold time, START to SCL	Source Side	4.0		μ s
$t_{su(3)}$	Internal register hold time, SCL to STOP	Source Side	4.0		μ s

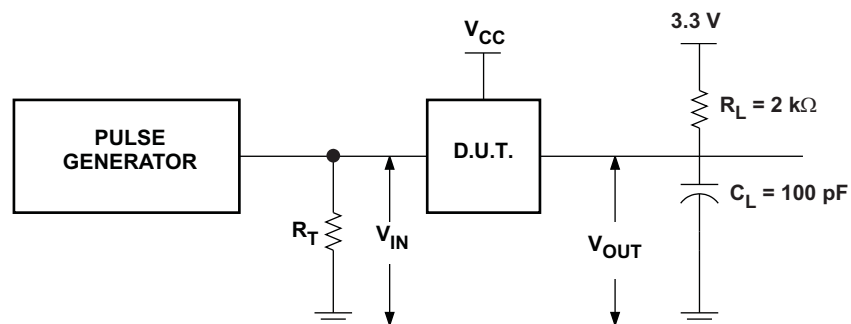

Figure 10. Source Side Test Circuit (SCL_SOURCE, SDA_SOURCE)

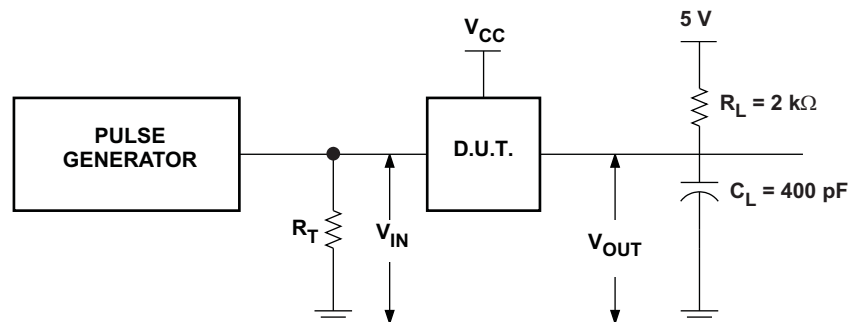

Figure 11. Sink Side Test Circuit (SCL_SINK, SDA_SINK)

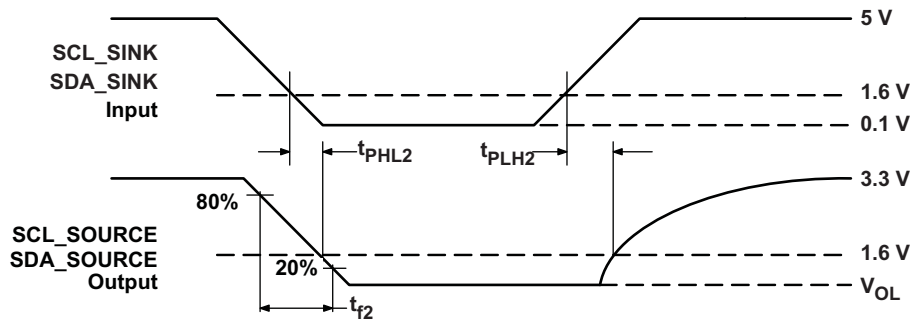

Figure 12. Source Side Output AC Measurements

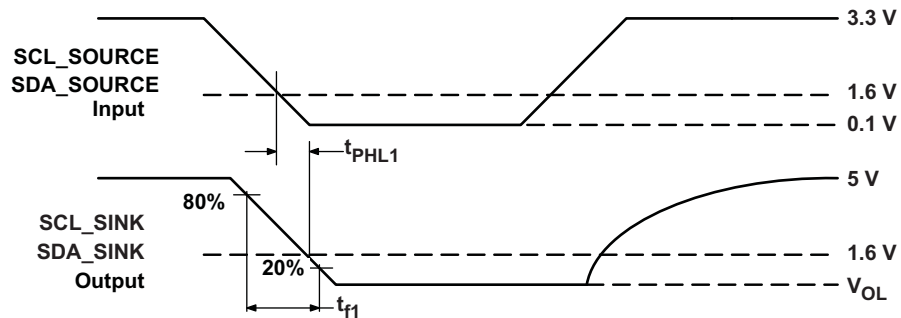

Figure 13. Sink Side Output AC Measurements

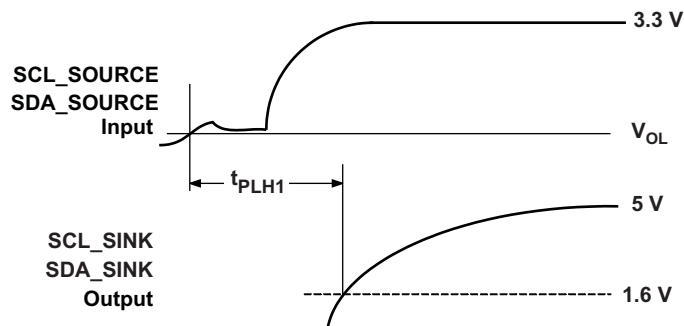

Figure 14. Sink Side Output AC Measurements Continued

TMDS and Main link pins

The main link inputs are designed to support DisplayPort 1.1 specification. The TMDS outputs of the SN75DP139 are designed to support the Digital Video Interface (DVI) 1.0 and High Definition Multimedia Interface (HDMI) 1.3 specifications. The differential output voltage swing can be fine tuned with the R_{Vsadj} resistor.

ELECTRICAL CHARACTERISTICS

over recommended operating conditions (unless otherwise noted)

PARAMETER		TEST CONDITIONS	MIN	TYP	MAX	UNIT
V _{OH}	Single-ended HIGH level output voltage	AVCC = 3.3 V, R _T = 50 Ω,	AVCC–10		AVCC+10	mV
V _{OL}	Single-ended LOW level output voltage		AVCC–600		AVCC+400	mV
V _{SWING}	Single-ended output voltage swing		400		600	mV
V _{OC(SS)}	Change in steady-state common-mode output voltage between logic states		–5		5	mV
V _{OD(PP)}	Peak-to-Peak output differential voltage		800		1200	mV
V _{(O)SBY}	Single-ended standby output voltage	AVCC = 3.3 V, R _T = 50 Ω, OE_N = High	AVCC–10		AVCC+10	mV
I _{(O)OFF}	Single-ended power down output current	0V ≤ VCC ≤ 1.5 V, AVCC = 3.3 V, R _T = 50Ω	–10		10	μA
I _{OS}	Short circuit output current	See Figure 19	–15		15	mA
R _{INT}	Input termination impedance		40	50	60	Ω
V _{term}	Input termination voltage		1		2	V

SWITCHING CHARACTERISTICS

over recommended operating conditions (unless otherwise noted)

PARAMETER		TEST CONDITIONS	MIN	TYP	MAX	UNIT	
t _{PLH}	Propagation delay time	AVCC=3.3 V, R _T = 50 Ω, f = 1MHz, R _{Vsadj} = 4.02 kΩ	250	350	600	ps	
t _{PHL}	Propagation delay time		250	350	600	ps	
t _{R1}	Rise Time (I2C_EN = HI, SRC = Hi-Z)		60	85	120	ps	
t _{F1}	Fall Time (I2C_EN = HI, SRC = Hi-Z)		60	85	120	ps	
t _{R2}	Rise Time (I2C_EN = Low, SRC = Hi-Z)			115	150	ps	
t _{F2}	Fall Time (I2C_EN = Low, SRC = Hi-Z)			115	150	ps	
t _{R3}	Rise Time (I2C_EN = HI, SRC = HI)			150	180	ps	
t _{F3}	Fall Time (I2C_EN = HI, SRC = HI)			150	180	ps	
t _{R4}	Rise Time (I2C_EN = HI, SRC = Low)			115	150	ps	
t _{F4}	Fall Time (I2C_EN = HI, SRC = Low)			115	150	ps	
t _{R5}	Rise Time (I2C_EN = Low, SRC = HI)			175	220	ps	
t _{F5}	Fall Time (I2C_EN = Low, SRC = HI)			175	220	ps	
t _{R6}	Rise Time (I2C_EN = Low, SRC = Low)			150	180	ps	
t _{F6}	Fall Time (I2C_EN = Low, SRC = Low)			150	180	ps	
t _{SK(P)}	Pulse skew				8	15	ps
t _{SK(D)}	Intra-pair skew				20	65	ps
t _{SK(O)}	Inter-pair skew				20	100	ps
t _{JITD(PP)}	Peak-to-peak output residual data jitter		AVCC = 3.3 V, R _T = 50Ω, dR=2.5Gbps, TMDS output slew rate (default). R _{Vsadj} = 4.02 kΩ (refer to Figure 18)		14	50	ps
t _{JITC(PP)}	Peak-to-peak output residual clock jitter	AVCC = 3.3 V, R _T = 50Ω, f = 250 MHz TMDS output slew rate (default). R _{Vsadj} = 4.02 kΩ (refer to Figure 18)		8	30	ps	

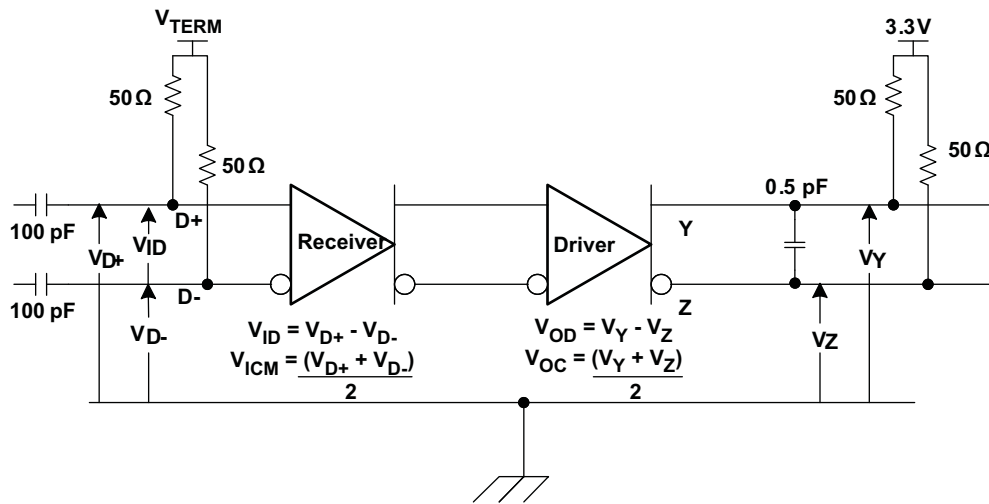

Figure 15. TMS Main Link Test Circuit

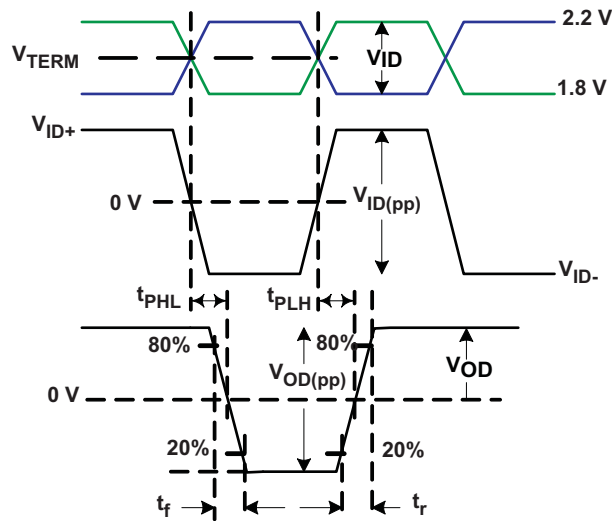

Figure 16. TMS Main Link Timing Measurements

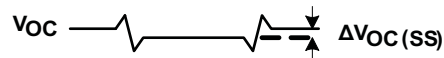
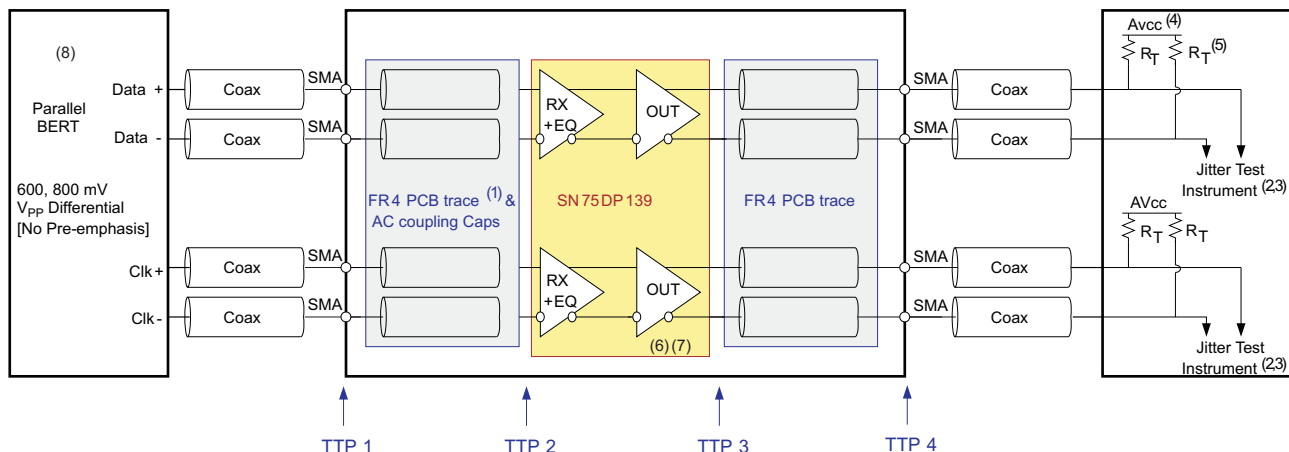

Figure 17. TMS Main Link Common Mode Measurements



1. The FR4 trace between TTP1 and TTP2 is designed to emulate 1-8" of FR4, AC coupling cap, connector and another 1-8" of FR4. Trace width - 4 mils.
2. All Jitter is measured at a BER of 10^{-8}
3. Residual jitter reflects the total jitter measured at TTP4 minus the jitter measured at TTP1
4. AVCC = 3.3V
5. RT = 50Ω.
6. Jitter data is taken with SN75DP139 configured in the fastest slew rate setting(default)
7. Rvsadj = 4.02kΩ
8. The input signal from parallel BERT does not have any pre-emphasis. Refer to recommended operating conditions

Figure 18. TMD5 Jitter Measurements

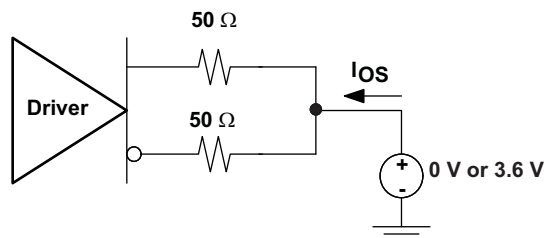

Figure 19. TMD5 Main Link Short Circuit Output Circuit

TYPICAL CHARACTERISTICS

AVCC = 3.3 V, $R_T = 50\Omega$, $R_{V_{sadj}} = 4.02\text{ k}\Omega$

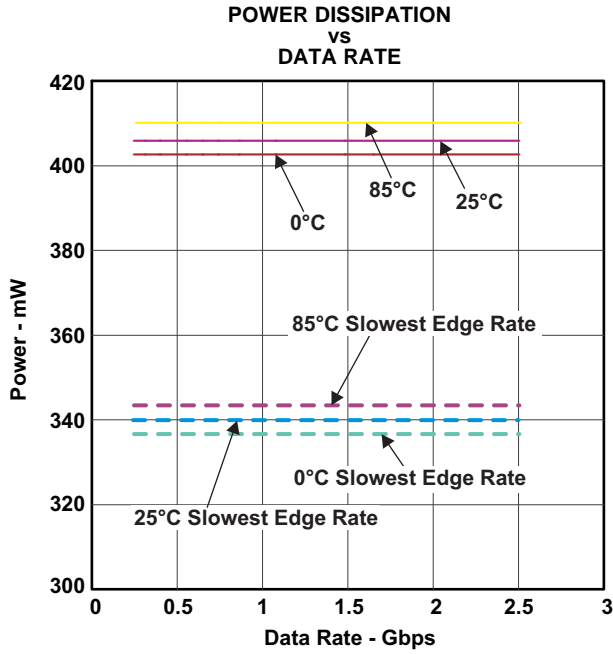

Figure 20.

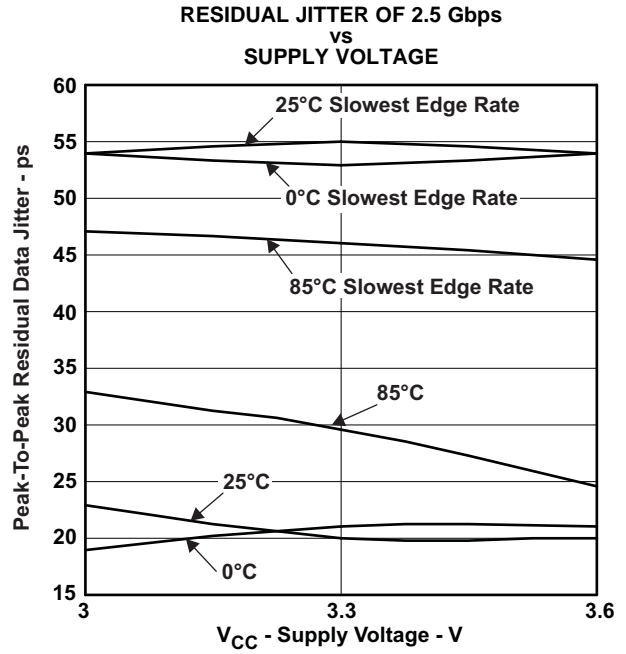

Figure 21.

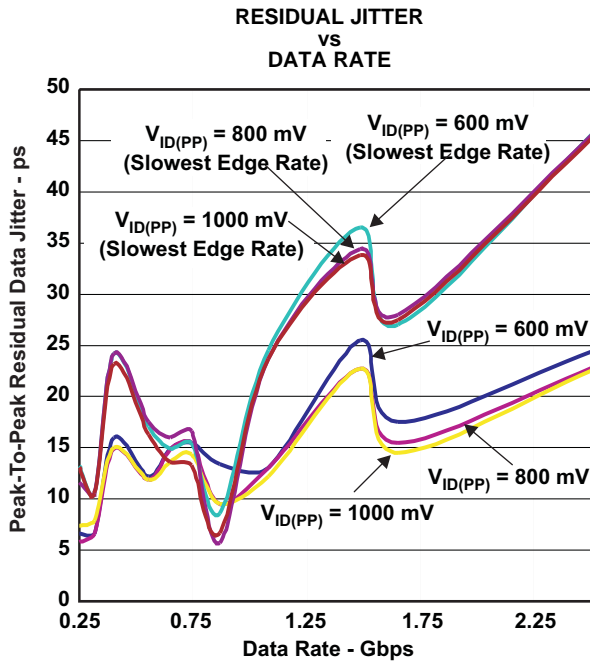

Figure 22.

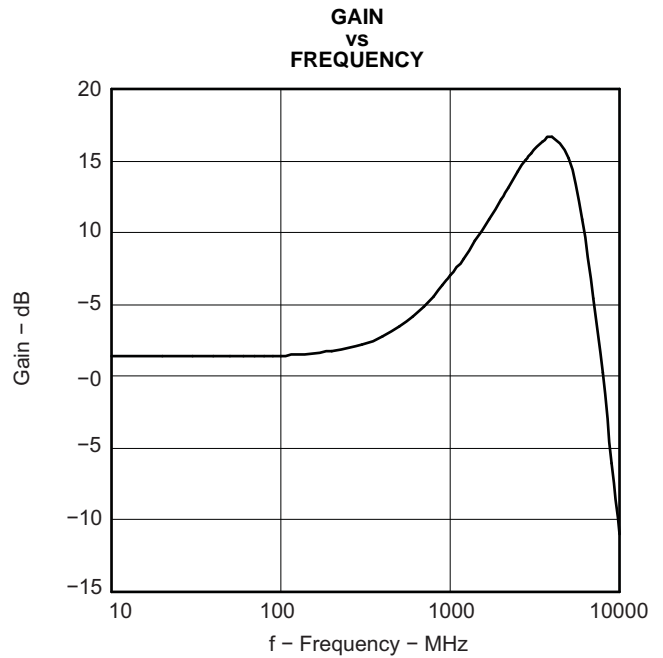

Figure 23.

TYPICAL CHARACTERISTICS (continued)

AVCC = 3.3 V, R_T = 50Ω

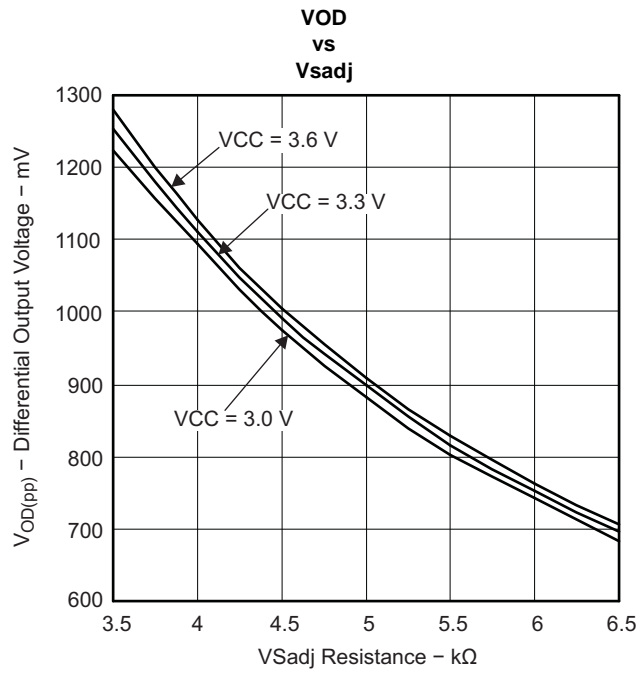

Figure 24.

APPLICATION INFORMATION

DVI APPLICATION

In DVI application case, it is recommended that between the SN75DP139 TMDS outputs (OUT_Dx) and a through hole DVI connector a series resistor placeholder is incorporated. This could help in case if there are signal integrity issues as well as help pass system level compliance.

I²C INTERFACE NOTES

The I²C interface can be used to access the internal memory of the SN75DP139. I²C is a two-wire serial interface developed by Philips Semiconductor (see I²C-Bus Specification, Version 2.1, January 2000). The bus consists of a data line (SDA) and a clock line (SCL) with pull-up structures. When the bus is *idle*, both SDA and SCL lines are pulled high. All the I²C compatible devices connect to the I²C bus through open drain I/O pins, SDA and SCL. A *master* device, usually a microcontroller or a digital signal processor, controls the bus. The master is responsible for generating the SCL signal and device addresses. The master also generates specific conditions that indicate the START and STOP of data transfer. A *slave* device receives and/or transmits data on the bus under control of the master device. The SN75DP139 works as a slave and supports the standard mode transfer (100 kbps) as defined in the I²C-Bus Specification.

The basic I²C start and stop access cycles are shown in [Figure 25](#).

The basic access cycle consists of the following:

- A start condition
- A slave address cycle
- Any number of data cycles
- A stop condition

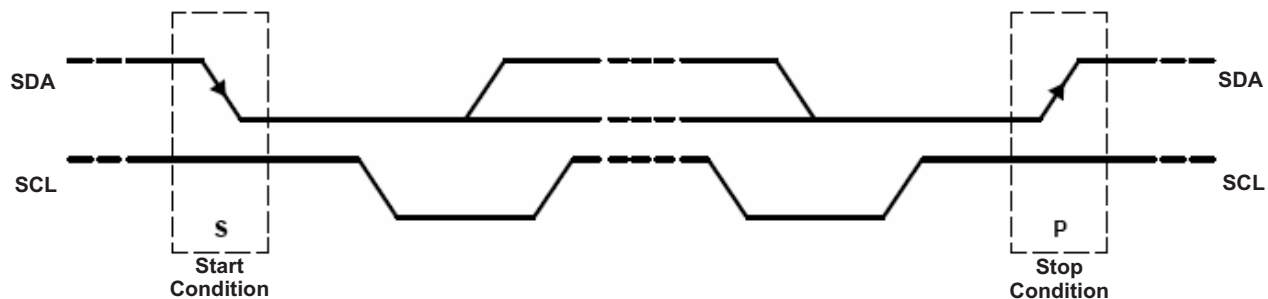

Figure 25. I²C Start and Stop Conditions

GENERAL I²C PROTOCOL

- The *master* initiates data transfer by generating a *start condition*. The *start condition* is when a high-to-low transition occurs on the SDA line while SCL is high, as shown in [Figure 27](#). All I²C-compatible devices should recognize a *start condition*.
- The master then generates the SCL pulses and transmits the 7-bit address and the *read/write direction bit* R/W on the SDA line. During all transmissions, the master ensures that data is *valid*. A *valid data condition* requires the SDA line to be stable during the entire high period of the clock pulse (see [Figure 26](#)). All devices recognize the address sent by the master and compare it to their internal fixed addresses. Only the slave device with a matching address generates an *acknowledge* (see [Figure 27](#)) by pulling the SDA line low during the entire high period of the ninth SCL cycle. On detecting this acknowledge, the master knows that a communication link with a slave has been established.
- The master generates further SCL cycles to either *transmit* data to the slave (R/W bit 0) or *receive* data from the slave (R/W bit 1). In either case, the receiver needs to acknowledge the data sent by the *transmitter*. So an acknowledge signal can either be generated by the master or by the slave, depending on which one is the receiver. The 9-bit valid data sequences consisting of 8-bit data and 1-bit acknowledge can continue as long as necessary (See [Figure 28](#)).
- To signal the end of the data transfer, the master generates a *stop condition* by pulling the SDA line from low to high while the SCL line is high (see [Figure 28](#)). This releases the bus and stops the communication link

with the addressed slave. All I²C compatible devices must recognize the stop condition. Upon the receipt of a *stop condition*, all devices know that the bus is released, and they wait for a *start condition* followed by a matching address.

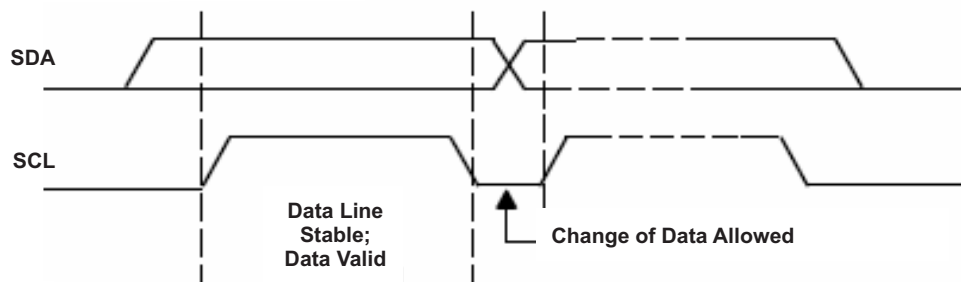

Figure 26. I²C Bit Transfer

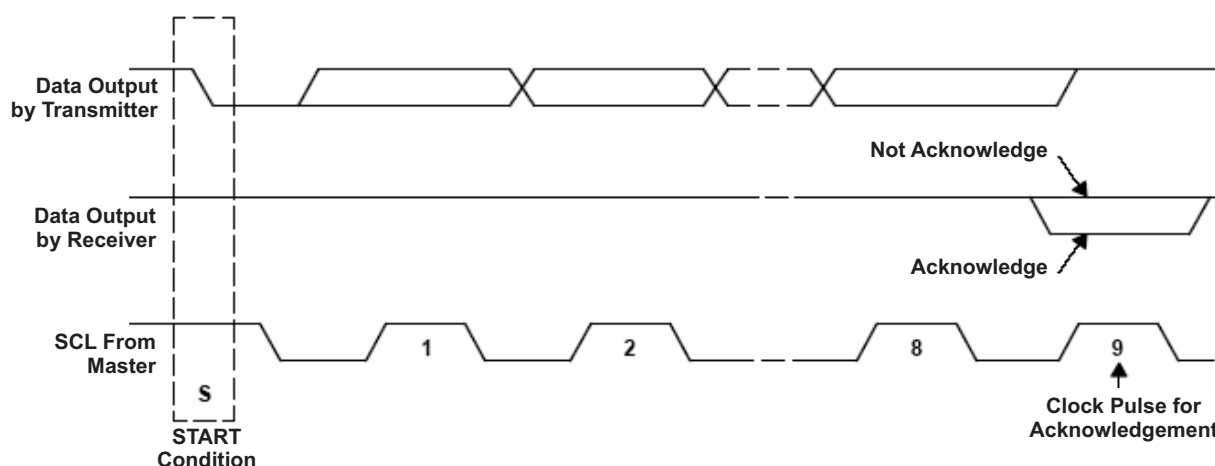

Figure 27. I²C Acknowledge

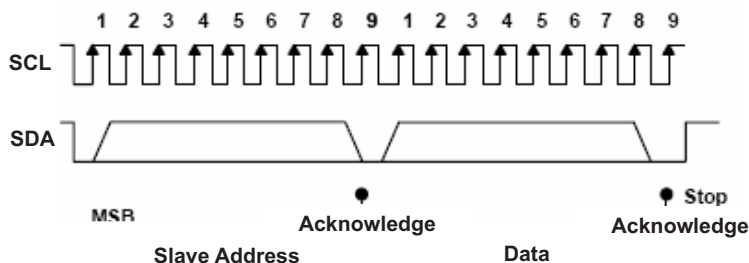

Figure 28. I²C Address and Data Cycles

During a read cycle, the slave receiver will acknowledge the initial address byte if it decodes the address as its address. Following this initial acknowledge by the slave, the master device becomes a receiver and acknowledges data bytes sent by the slave. When the master has received all of the requested data bytes from the slave, the not acknowledge (A) condition is initiated by the master by keeping the SDA signal high just before it asserts the stop (P) condition. This sequence terminates a read cycle as shown in Figure 29 and Figure 30. See Example – Reading from the SN75DP139 section for more information.

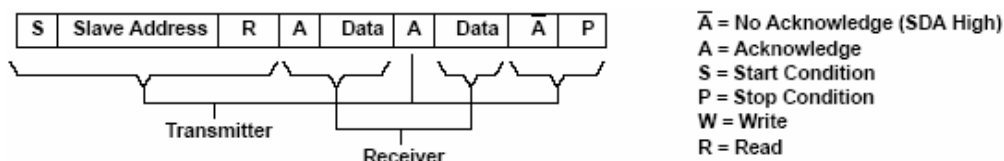

Figure 29. I²C Read Cycle

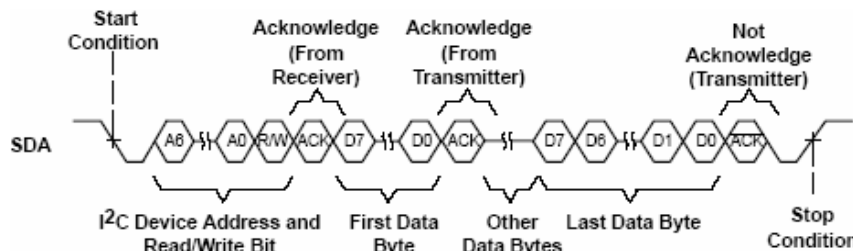

Figure 30. Multiple Byte Read Transfer

SLAVE ADDRESS

Both SDA and SCL must be connected to a positive supply voltage via a pull-up resistor. These resistors should comply with the I²C specification that ranges from 2kΩ to 19kΩ. When the bus is free, both lines are high. The address byte is the first byte received following the START condition from the master device. The 7 bit address is factory preset to 1000000. Table 2 lists the calls that the SN75DP139 will respond to.

Table 2. SN75DP139 Slave Address

Fixed Address							Read/Write Bit
Bit 7 (MSB)	Bit 6	Bit 5	Bit 4	Bit 3	Bit 2	Bit 1	Bit 0 (R/W)
1	0	0	0	0	0	0	1

Sink Port Selection Register and Source Plug-In Status Register Description (Sub-Address)

The SN75DP139 operates using a multiple byte transfer protocol similar to Figure 30. The internal memory of the SN75DP139 contains the phrase “DP-HDMI ADAPTOR<EOT>” converted to ASCII characters. The internal memory address registers and the value of each can be found in Table 3.

During a read cycle, the SN75DP139 will send the data in its selected sub-address in a single transfer to the master device requesting the information. See the **Example – Reading from the SN75DP139** section of this document for the proper procedure on reading from the SN75DP139.

Table 3. SN75DP139 Sink Port and Source Plug-In Status Registers Selection

Address	0x00	0x01	0x02	0x03	0x04	0x05	0x06	0x07	0x08	0x09	0x0A	0x0B	0x0C	0x0D	0x0E	0x0F	0x10
Data	44	50	2D	48	44	4D	49	20	41	44	41	50	54	4F	52	04	FF

EXAMPLE – READING FROM THE SN75DP139:

The read operation consists of several steps. The I²C master begins the communication with the transmission of the start sequence followed by the slave address of the SN75DP139 and logic address of 00h. The SN75DP139 will acknowledge its presence to the master and begin to transmit the contents of the memory registers. After each byte is transferred the SN75DP139 will wait for either an acknowledge (ACK) or a not-acknowledge (NACK) from the master. If an ACK is received the next byte of data will be transmitted. If a NACK is received the data transmission sequence is expected to end and the master should send the stop command.

The SN75DP139 will continue to send data as long as the master continues to acknowledge each byte transmission. If an ACK is received after the transmission of byte 0x0F the SN75DP139 will transmit byte 0x10 and continue to transmit byte 0x10 for all further ACK's until a NACK is received.

The SN75DP139 also supports an accelerated read mode where steps 1–6 can be skipped.

SN75DP139 Read Phase

Step 1	0							
I ² C Start (Master)	S							
Step 2	7	6	5	4	3	2	1	0
I ² C General Address Write (Master)	1	0	0	0	0	0	0	0
Step 3	9							
I ² C Acknowledge (Slave)	A							
Step 4	7	6	5	4	3	2	1	0
I ² C Logic Address (Master)	0	0	0	0	0	0	0	0
Step 5	9							
I ² C Acknowledge (Slave)	A							
Step 6	0							
I ² C Stop (Master)	P							
Step 7	0							
I ² C Start (Master)	S							
Step 8	7	6	5	4	3	2	1	0
I ² C General Address Read (Master)	1	0	0	0	0	0	0	1
Step 9	9							
I ² C Acknowledge (Slave)	A							
Step 10	7	6	5	4	3	2	1	0
I ² C Read Data (Slave)	Data	Data	Data	Data	Data	Data	Data	Data

Where Data is determined by the Logic values Contained in the Sink Port Register

Step 11	9
I ² C Not-Acknowledge (Master)	X

Where X is an A (Acknowledge) or \bar{A} (Not-Acknowledge)

An A causes the pointer to increment and step 10 is repeated.

An \bar{A} causes the slave to stop transmitting and proceeds to step 12.

Step 12	0
I ² C Stop (Master)	P

RGZ (S-PQFP-N48)

PLASTIC QUAD FLATPACK

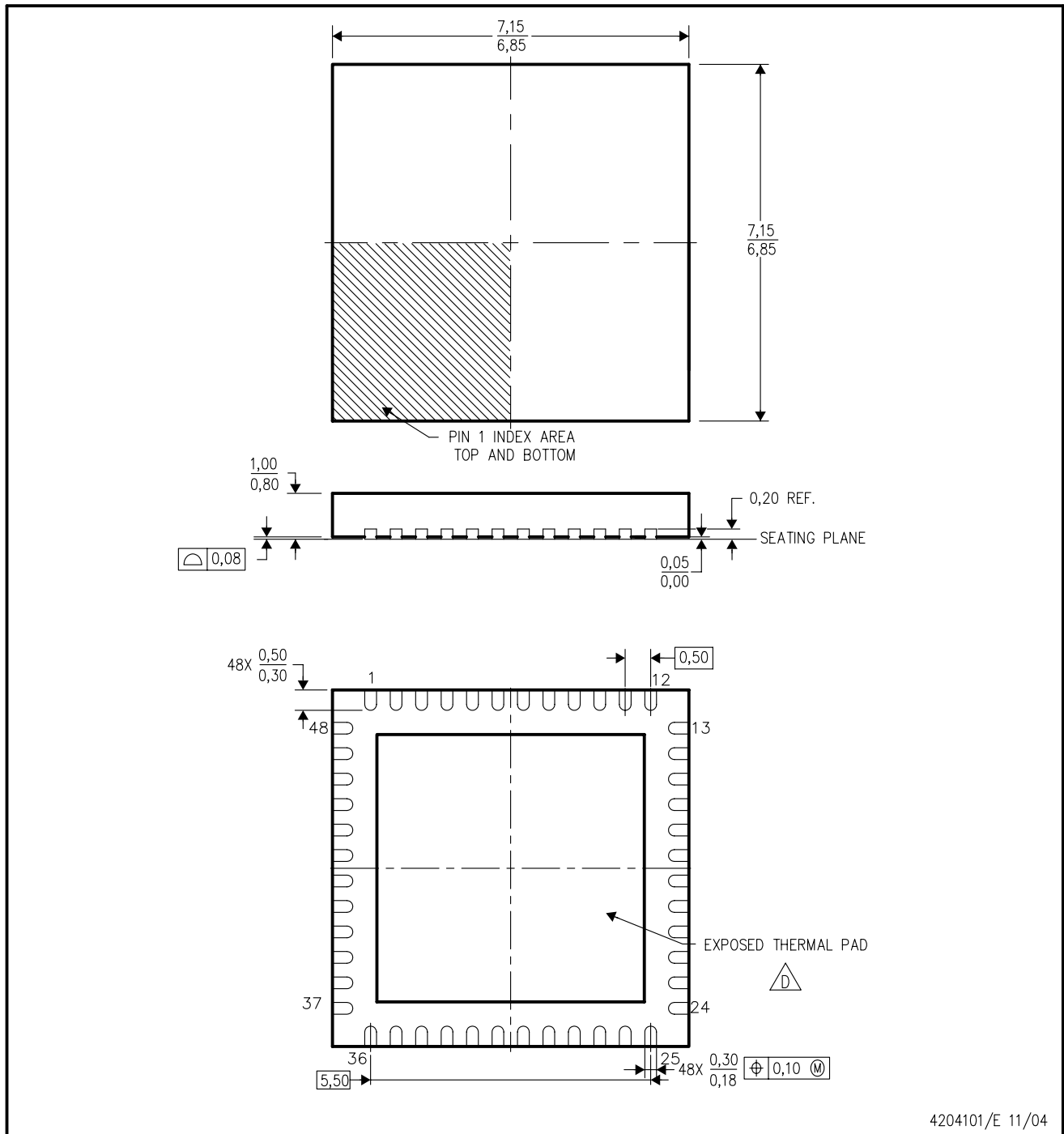

- NOTES:
- A. All linear dimensions are in millimeters. Dimensioning and tolerancing per ASME Y14.5M-1994.
 - B. This drawing is subject to change without notice.
 - C. Quad Flatpack, No-leads (QFN) package configuration.
 - D. The package thermal pad must be soldered to the board for thermal and mechanical performance. See the Product Data Sheet for details regarding the exposed thermal pad dimensions.
 - E. Falls within JEDEC MO-220.

THERMAL INFORMATION

This package incorporates an exposed thermal pad that is designed to be attached directly to an external heatsink. The thermal pad must be soldered directly to the printed circuit board (PCB). After soldering, the PCB can be used as a heatsink. In addition, through the use of thermal vias, the thermal pad can be attached directly to the appropriate copper plane shown in the electrical schematic for the device, or alternatively, can be attached to a special heatsink structure designed into the PCB. This design optimizes the heat transfer from the integrated circuit (IC).

For information on the Quad Flatpack No-Lead (QFN) package and its advantages, refer to Application Report, QFN/SON PCB Attachment, Texas Instruments Literature No. SLUA271. This document is available at www.ti.com.

The exposed thermal pad dimensions for this package are shown in the following illustration.

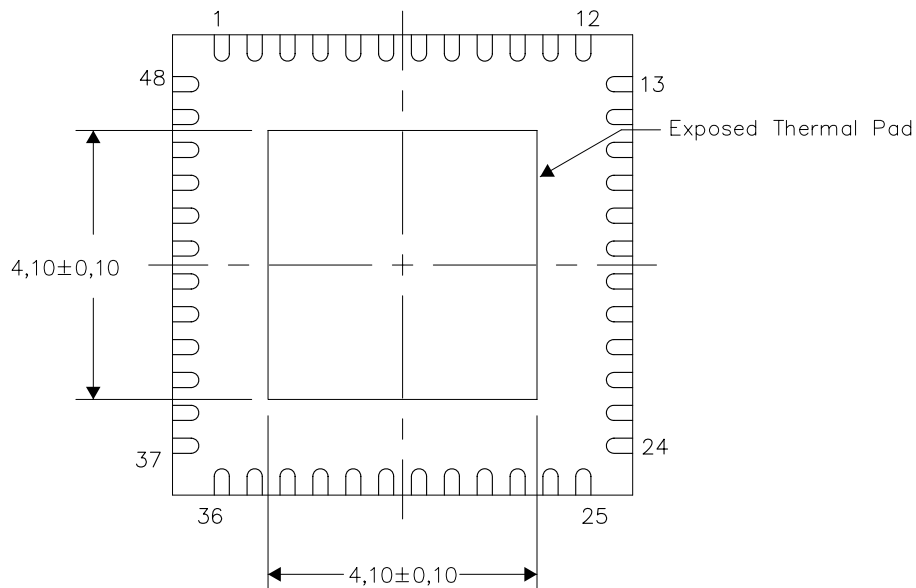

Bottom View

NOTE: All linear dimensions are in millimeters

Exposed Thermal Pad Dimensions

RGZ (S-PVQFN-N48)

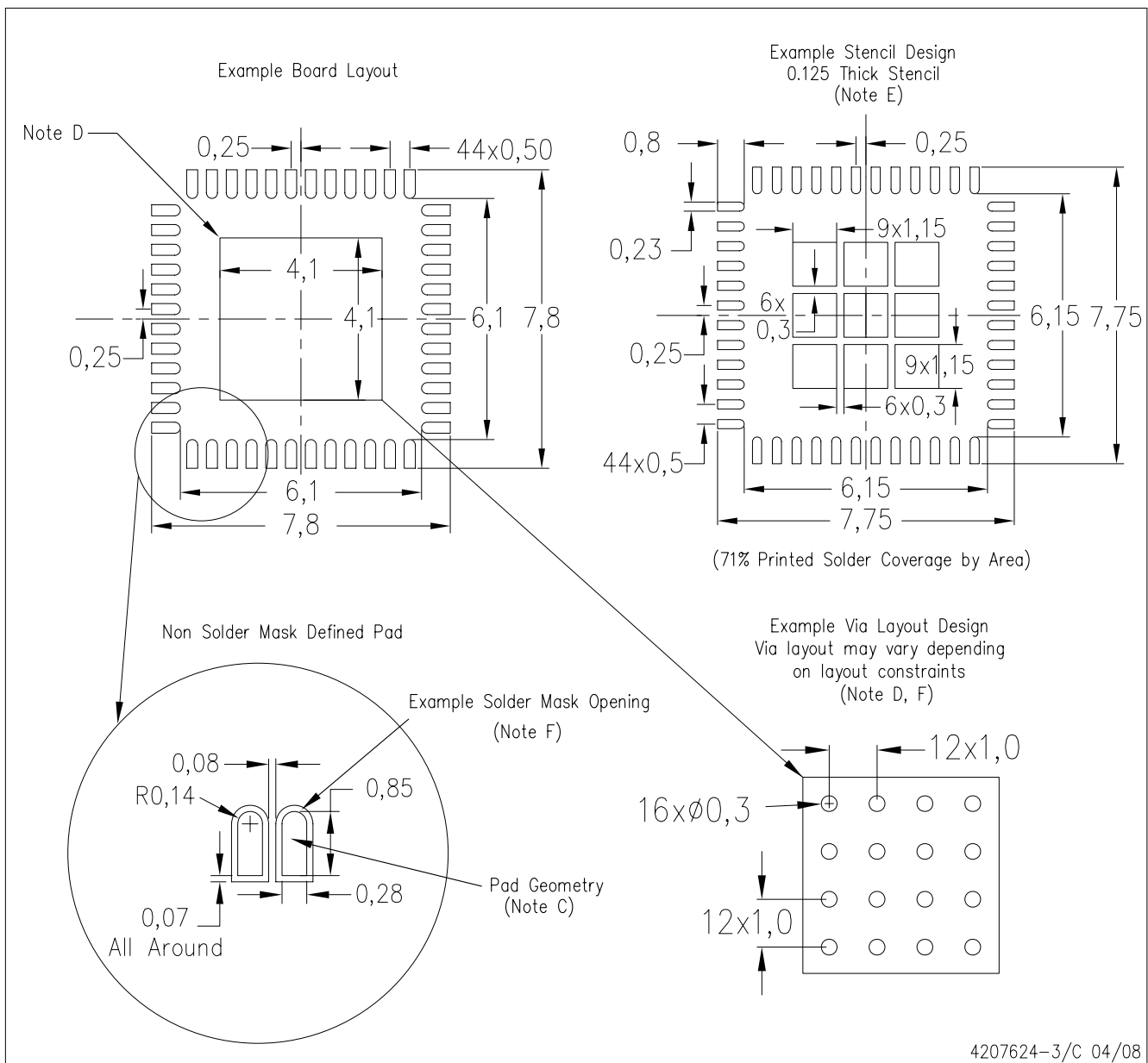

- NOTES:
- All linear dimensions are in millimeters.
 - This drawing is subject to change without notice.
 - Publication IPC-7351 is recommended for alternate designs.
 - This package is designed to be soldered to a thermal pad on the board. Refer to Application Note, Quad Flat-Pack Packages, Texas Instruments Literature No. SCBA017, SLUA271, and also the Product Data Sheets for specific thermal information, via requirements, and recommended board layout. These documents are available at www.ti.com <<http://www.ti.com>>.
 - Laser cutting apertures with trapezoidal walls and also rounding corners will offer better paste release. Customers should contact their board assembly site for stencil design recommendations. Refer to IPC 7525 for stencil design considerations.
 - Customers should contact their board fabrication site for recommended solder mask tolerances and via tenting recommendations for vias placed in the thermal pad.

PACKAGING INFORMATION

Orderable Device	Status ⁽¹⁾	Package Type	Package Drawing	Pins	Package Qty	Eco Plan ⁽²⁾	Lead/Ball Finish	MSL Peak Temp ⁽³⁾
SN75DP139RGZR	ACTIVE	QFN	RGZ	48	2500	Green (RoHS & no Sb/Br)	CU NIPDAU	Level-3-260C-168 HR
SN75DP139RGZT	ACTIVE	QFN	RGZ	48	250	Green (RoHS & no Sb/Br)	CU NIPDAU	Level-3-260C-168 HR

⁽¹⁾ The marketing status values are defined as follows:

ACTIVE: Product device recommended for new designs.

LIFEBUY: TI has announced that the device will be discontinued, and a lifetime-buy period is in effect.

NRND: Not recommended for new designs. Device is in production to support existing customers, but TI does not recommend using this part in a new design.

PREVIEW: Device has been announced but is not in production. Samples may or may not be available.

OBsolete: TI has discontinued the production of the device.

⁽²⁾ Eco Plan - The planned eco-friendly classification: Pb-Free (RoHS), Pb-Free (RoHS Exempt), or Green (RoHS & no Sb/Br) - please check <http://www.ti.com/productcontent> for the latest availability information and additional product content details.

TBD: The Pb-Free/Green conversion plan has not been defined.

Pb-Free (RoHS): TI's terms "Lead-Free" or "Pb-Free" mean semiconductor products that are compatible with the current RoHS requirements for all 6 substances, including the requirement that lead not exceed 0.1% by weight in homogeneous materials. Where designed to be soldered at high temperatures, TI Pb-Free products are suitable for use in specified lead-free processes.

Pb-Free (RoHS Exempt): This component has a RoHS exemption for either 1) lead-based flip-chip solder bumps used between the die and package, or 2) lead-based die adhesive used between the die and leadframe. The component is otherwise considered Pb-Free (RoHS compatible) as defined above.

Green (RoHS & no Sb/Br): TI defines "Green" to mean Pb-Free (RoHS compatible), and free of Bromine (Br) and Antimony (Sb) based flame retardants (Br or Sb do not exceed 0.1% by weight in homogeneous material)

⁽³⁾ MSL, Peak Temp. -- The Moisture Sensitivity Level rating according to the JEDEC industry standard classifications, and peak solder temperature.

Important Information and Disclaimer:The information provided on this page represents TI's knowledge and belief as of the date that it is provided. TI bases its knowledge and belief on information provided by third parties, and makes no representation or warranty as to the accuracy of such information. Efforts are underway to better integrate information from third parties. TI has taken and continues to take reasonable steps to provide representative and accurate information but may not have conducted destructive testing or chemical analysis on incoming materials and chemicals. TI and TI suppliers consider certain information to be proprietary, and thus CAS numbers and other limited information may not be available for release.

In no event shall TI's liability arising out of such information exceed the total purchase price of the TI part(s) at issue in this document sold by TI to Customer on an annual basis.

TAPE AND REEL INFORMATION



QUADRANT ASSIGNMENTS FOR PIN 1 ORIENTATION IN TAPE



*All dimensions are nominal

Device	Package Type	Package Drawing	Pins	SPQ	Reel Diameter (mm)	Reel Width W1 (mm)	A0 (mm)	B0 (mm)	K0 (mm)	P1 (mm)	W (mm)	Pin1 Quadrant
SN75DP139RGZR	QFN	RGZ	48	2500	330.0	16.4	7.3	7.3	1.5	12.0	16.0	Q2
SN75DP139RGZT	QFN	RGZ	48	250	180.0	16.4	7.3	7.3	1.5	12.0	16.0	Q2

TAPE AND REEL BOX DIMENSIONS



*All dimensions are nominal

Device	Package Type	Package Drawing	Pins	SPQ	Length (mm)	Width (mm)	Height (mm)
SN75DP139RGZR	QFN	RGZ	48	2500	346.0	346.0	33.0
SN75DP139RGZT	QFN	RGZ	48	250	190.5	212.7	31.8

IMPORTANT NOTICE

Texas Instruments Incorporated and its subsidiaries (TI) reserve the right to make corrections, modifications, enhancements, improvements, and other changes to its products and services at any time and to discontinue any product or service without notice. Customers should obtain the latest relevant information before placing orders and should verify that such information is current and complete. All products are sold subject to TI's terms and conditions of sale supplied at the time of order acknowledgment.

TI warrants performance of its hardware products to the specifications applicable at the time of sale in accordance with TI's standard warranty. Testing and other quality control techniques are used to the extent TI deems necessary to support this warranty. Except where mandated by government requirements, testing of all parameters of each product is not necessarily performed.

TI assumes no liability for applications assistance or customer product design. Customers are responsible for their products and applications using TI components. To minimize the risks associated with customer products and applications, customers should provide adequate design and operating safeguards.

TI does not warrant or represent that any license, either express or implied, is granted under any TI patent right, copyright, mask work right, or other TI intellectual property right relating to any combination, machine, or process in which TI products or services are used. Information published by TI regarding third-party products or services does not constitute a license from TI to use such products or services or a warranty or endorsement thereof. Use of such information may require a license from a third party under the patents or other intellectual property of the third party, or a license from TI under the patents or other intellectual property of TI.

Reproduction of TI information in TI data books or data sheets is permissible only if reproduction is without alteration and is accompanied by all associated warranties, conditions, limitations, and notices. Reproduction of this information with alteration is an unfair and deceptive business practice. TI is not responsible or liable for such altered documentation. Information of third parties may be subject to additional restrictions.

Resale of TI products or services with statements different from or beyond the parameters stated by TI for that product or service voids all express and any implied warranties for the associated TI product or service and is an unfair and deceptive business practice. TI is not responsible or liable for any such statements.

TI products are not authorized for use in safety-critical applications (such as life support) where a failure of the TI product would reasonably be expected to cause severe personal injury or death, unless officers of the parties have executed an agreement specifically governing such use. Buyers represent that they have all necessary expertise in the safety and regulatory ramifications of their applications, and acknowledge and agree that they are solely responsible for all legal, regulatory and safety-related requirements concerning their products and any use of TI products in such safety-critical applications, notwithstanding any applications-related information or support that may be provided by TI. Further, Buyers must fully indemnify TI and its representatives against any damages arising out of the use of TI products in such safety-critical applications.

TI products are neither designed nor intended for use in military/aerospace applications or environments unless the TI products are specifically designated by TI as military-grade or "enhanced plastic." Only products designated by TI as military-grade meet military specifications. Buyers acknowledge and agree that any such use of TI products which TI has not designated as military-grade is solely at the Buyer's risk, and that they are solely responsible for compliance with all legal and regulatory requirements in connection with such use.

TI products are neither designed nor intended for use in automotive applications or environments unless the specific TI products are designated by TI as compliant with ISO/TS 16949 requirements. Buyers acknowledge and agree that, if they use any non-designated products in automotive applications, TI will not be responsible for any failure to meet such requirements.

Following are URLs where you can obtain information on other Texas Instruments products and application solutions:

Products

Amplifiers	amplifier.ti.com
Data Converters	dataconverter.ti.com
DLP® Products	www.dlp.com
DSP	dsp.ti.com
Clocks and Timers	www.ti.com/clocks
Interface	interface.ti.com
Logic	logic.ti.com
Power Mgmt	power.ti.com
Microcontrollers	microcontroller.ti.com
RFID	www.ti-rfid.com
RF/IF and ZigBee® Solutions	www.ti.com/lprf

Applications

Audio	www.ti.com/audio
Automotive	www.ti.com/automotive
Broadband	www.ti.com/broadband
Digital Control	www.ti.com/digitalcontrol
Medical	www.ti.com/medical
Military	www.ti.com/military
Optical Networking	www.ti.com/opticalnetwork
Security	www.ti.com/security
Telephony	www.ti.com/telephony
Video & Imaging	www.ti.com/video
Wireless	www.ti.com/wireless

Mailing Address: Texas Instruments, Post Office Box 655303, Dallas, Texas 75265
Copyright © 2009, Texas Instruments Incorporated