

SPECIFICATION:

BLGDEP133UT1

1. General Description

reflective electrophoretic E Ink technology display module based on active matrix TFT substrate. It has 13.3” active area with 1600 x 1200 pixels, the display is capable to display images at 2-16 gray levels (1-4 bits) depending on the display controller and the associated waveform file it used.

2. Features

- High contrast reflective / electrophoretic technology
- 1600x1200 display
- High reflectance
- Ultra wide viewing angle
- Ultra low power consumption
- Pure reflective mode
- Bi-stable
- Commercial temperature range
- Antiglare hard-coated front-surface

3. Mechanical Specifications

Parameter	Specifications	Unit	Remark
Screen Size	13.3	Inch	
Display Resolution	1600 (H)×1200(V)	Pixel	
Active Area	270.4 (H)×202.8 (V)	mm	
Pixel Pitch	0.169 (H)×0.169 (V)	mm	
Pixel Configuration	Rectangle		
Outline Dimension	285.8(W)×213.65(H)×0.994(D) (panel area height)	mm	
Module Weight	116±10	g	
Number of Gray	16 Gray Level (monochrome)		
Display operating mode	Reflective mode		
Surface treatment	Anti-glare treatment for protective sheet		

4. Mechanical Drawing of EPD Module

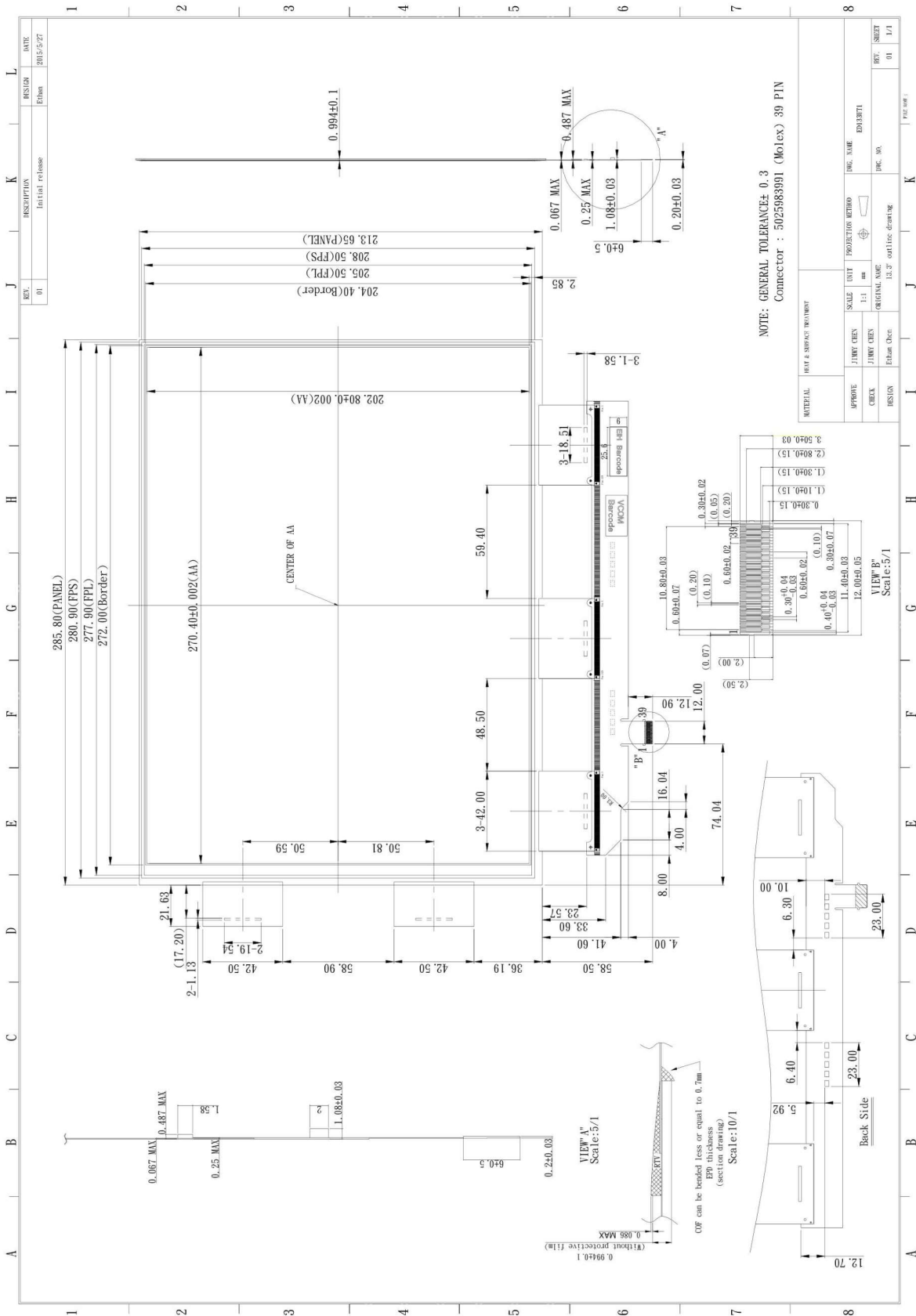

5. Input/Output Interface

5-1) Pin Assignment

Pin	Signal	Description	Remark
1	VNEG	Negative power supply source driver	
2	VPOS	Positive power supply source driver	
3	VSS	Ground	
4	VDD	Digital power supply drivers	
5	XCL	Clock source driver	
6	XLE	Latch enable source driver	
7	XOE	Output enable source driver	
8	VSS	Ground	
9	VSS	Ground	
10	NC	No Connection	
11	XSTL	Start pulse source driver	
12	D0	Data signal source driver	
13	D1	Data signal source driver	
14	D2	Data signal source driver	
15	D3	Data signal source driver	
16	D4	Data signal source driver	
17	D5	Data signal source driver	
18	D6	Data signal source driver	
19	D7	Data signal source driver	
20	VSS	Ground	
21	NC	No Connection	
22	VCOM	Common connection	
23	VGH	Positive power supply gate driver	
24	VGL	Negative power supply gate driver	
25	NC	No Connection	
26	NC	No Connection	
27	NC	No Connection	
28	MODE1	Output mode selection gate driver	
29	VSS	Ground	
30	VSS	Ground	
31	VSS	Ground	
32	SPV	Start pulse gate driver	
33	CKV	Clock gate driver	
34	BORDER	Border connection	
35	VSS	Ground	
36	VSS	Ground	
37	VSS	Ground	
38	VSS	Ground	
39	VSS	Ground	

6. Electrical Characteristics

6-1) Absolute maximum rating

Parameter	Symbol	Rating	Unit
Logic Supply Voltage	VDD	-0.3 to +7	V
Positive Supply Voltage	V _{POS}	-0.3 to +18	V
Negative Supply Voltage	V _{NEG}	+0.3 to -18	V
Max .Drive Voltage Range	V _{POS} - V _{NEG}	36	V
Supply Voltage	VGH	-0.3 to +55	V
Supply Voltage	VGL	-32 to +0.3	V
Supply Range	VGH-VGL	-0.3 to +55	V
Operating Temp. Range	TOTR	0 to +50	°C
Storage Temperature	TSTG	-25 to +70	°C

6-2) Panel DC characteristics

Parameter	symbol	conditions	Min	Typ	Max	Unit
Signal ground	VSS			0		V
Logic voltage supply	VDD		2.75	3.3	3.6	V
	I _{DD}	VDD=3.3V		2.5	10	mA
Gate negative supply	VGL		-19	-20	-21	V
	I _{GL}	VGL=-20V		1.3	4.0	mA
Gate Positive supply	VGH		26	27	28	V
	I _{GH}	VGH=27V		1.3	4.0	mA
Source negative supply	V _{NEG}		-15.4	-15	-14.6	V
	I _{NEG}	V _{NEG} =-15V		6	135	mA
Source Positive supply	V _{POS}		14.6	15	15.4	V
	I _{POS}	V _{POS} =15V		6	135	mA
Border supply	Vcom		-2.5	Adjusted	-0.3	V
Asymmetry source	Vasm	V _{pos} +V _{neg}	-800		800	mV
Common voltage	Vcom		-2.5	Adjusted	-0.3	V
	Icom			0.42	0.8	mA
Maxmum Power panel	Pmax				4300	mW
Typcal power panel	Ptyp			265		mW
Standby power panel	Pstby				0.4	mW

- The maximum power consumption is measured at 65 Hz operation with following pattern transition: from pattern of repeated 1 consecutive black scan lines followed by 1 consecutive white scan line to that of repeated 1 consecutive white scan lines followed by 1 consecutive black scan lines.(Note 6-1)
- The Typical power consumption is measured at 65 Hz operation with following pattern transition: from horizontal 4 gray scale pattern to vertical 4 gray scale pattern.(Note 6-2)
- The standby power is the consumed power when the panel controller is in standby mode.
- The listed electrical/optical characteristics are only guaranteed under the controller & waveform provided by Good Display.
- Vcom is recommended to be set in the range of assigned value $\pm 0.1V$

Note 6-1

The maximum power consumption

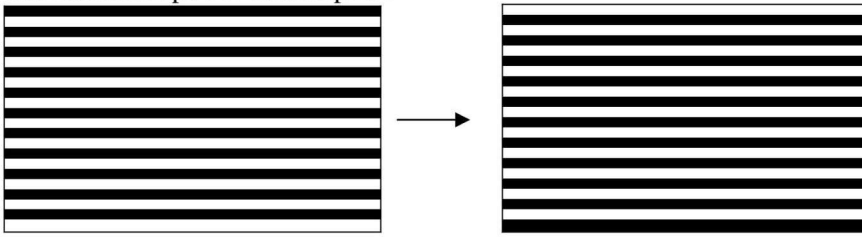

Note 6-2

The Typical power consumption

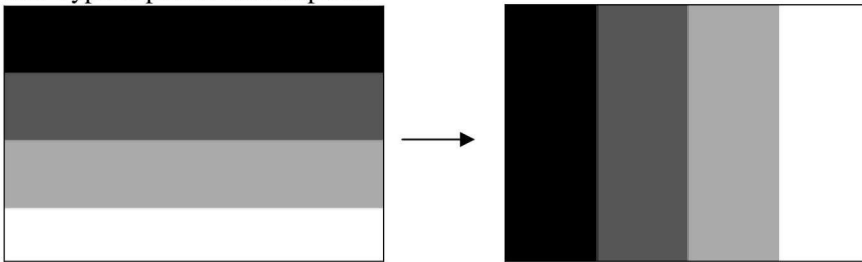

6-3) Refresh Rate

The module GDEP133UT1 is applied at a maximum screen refresh rate of 65Hz.

	Min	Max
Refresh Rate	-	65Hz

6-4) Panel AC characteristics

VDD=2.73V to 3.6V, unless otherwise specified.

Parameter	Symbol	Min.	Typ.	Max.	Unit
Clock frequency	fckv	-	-	200	kHz
Minimum “L” clock pulse width	twL	0.5	-	-	us
Minimum “H” clock pulse width	twH	0.5	-	-	us
Clock rise time	trckv	-	-	100	ns
Clock fall time	tfckv	-	-	100	ns
SPV setup time	tSU	100	-	twH-100	ns
SPV hold time	tH	100	-	twH-100	ns
Pulse rise time	trspv	-	-	100	ns
Pulse fall time	tfspv	-	-	100	ns
Clock XCL cycle time	tey	16.7	-	-	ns
D0 .. D7 setup time	tsu	8	-	-	ns
D0 .. D7 hold time	th	8	-	-	ns
XSTL setup time	tstls	8.35	-	-	ns
XSTL hold time	tstlh	8.35	-	-	ns
XLE on delay time	tLEdly	40	-	-	ns
XLE high-level pulse width (When VDD=2.73V to 3.6V)	tLEw	40	-	-	ns
XLE off delay time	tLEoff	200	-	-	ns
Output setting time to +/- 30mV(C _{load} =200pF)	tout	-	-	12	us
Frame Sync Length (Mode 1)	t1	1			1 line

OUTPUT LATCH CONTROL SIGNALS

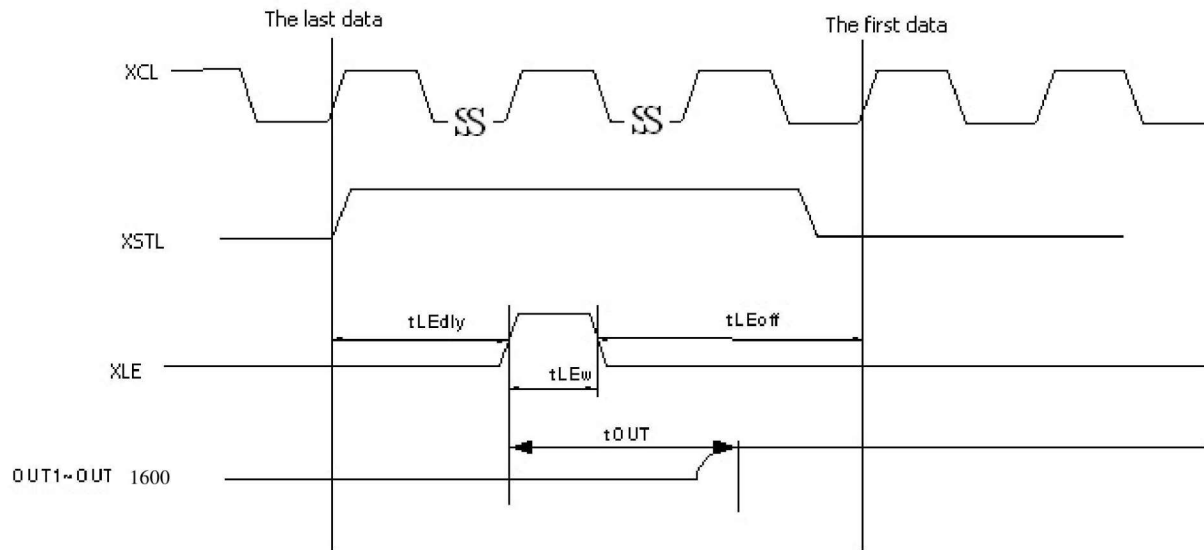

CLOCK & DATA TIMING

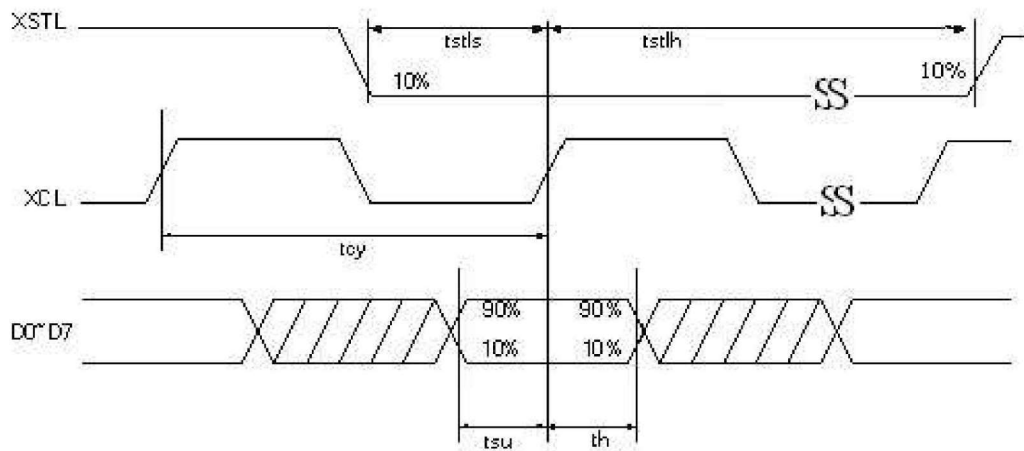

CKV & SPV TIMING

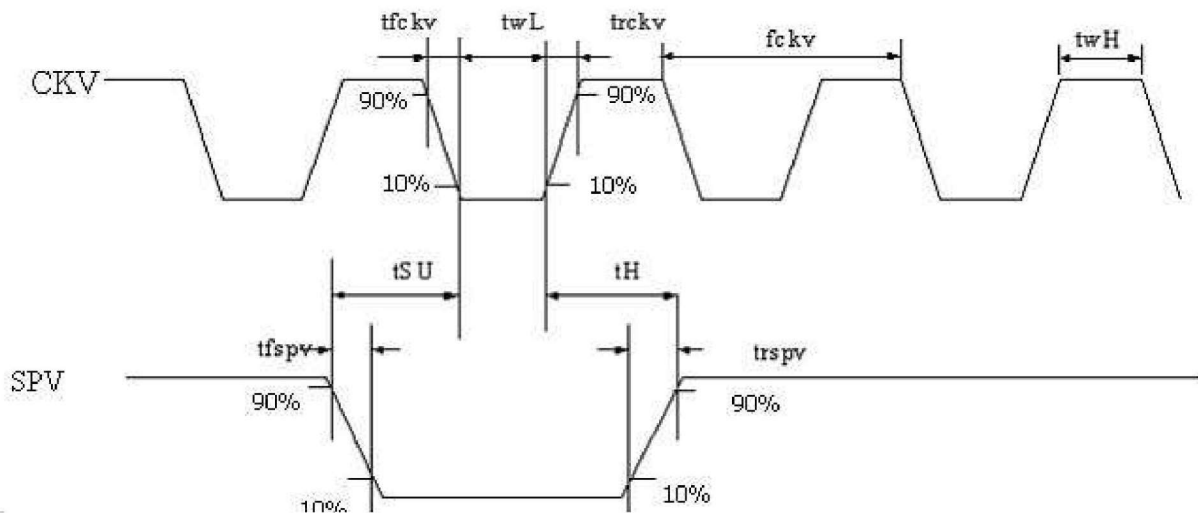

GATE OUTPUT TIMING

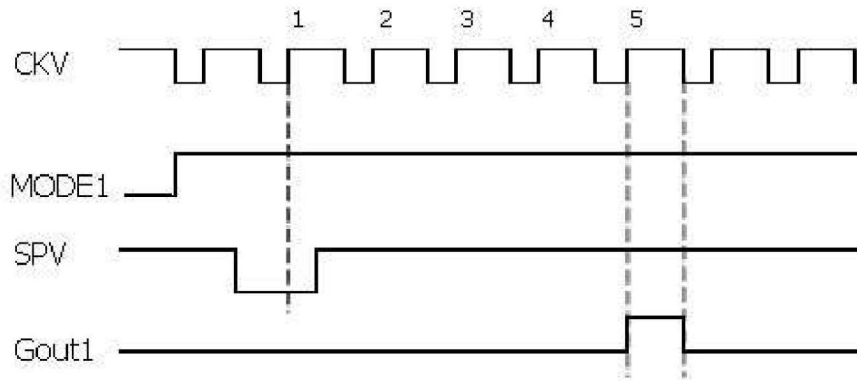

Frame Sync Length

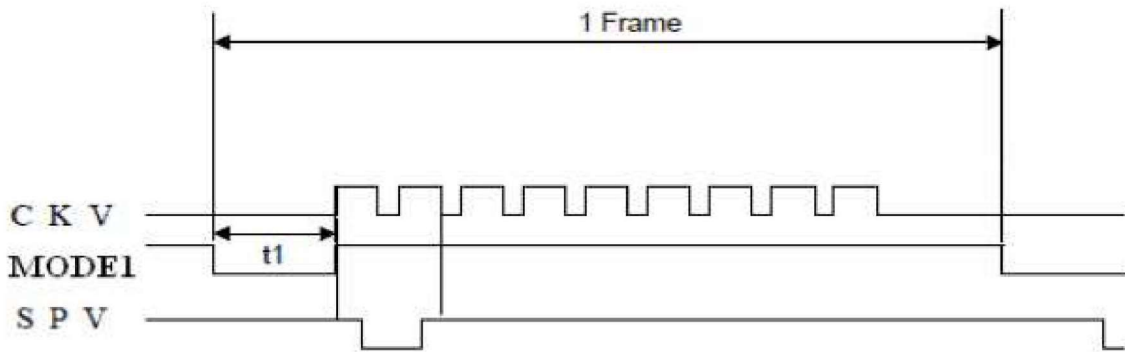

Note : First gate line on timing
After 5CKV , gate line is on .

7. Power Sequence

Power Rails must be sequenced in the following order :

1. VSS → VDD → VNEG → VPOS (Source driver) → VCOM

2. VSS → VDD → VGL → VGH (Gate driver)

POWER ON

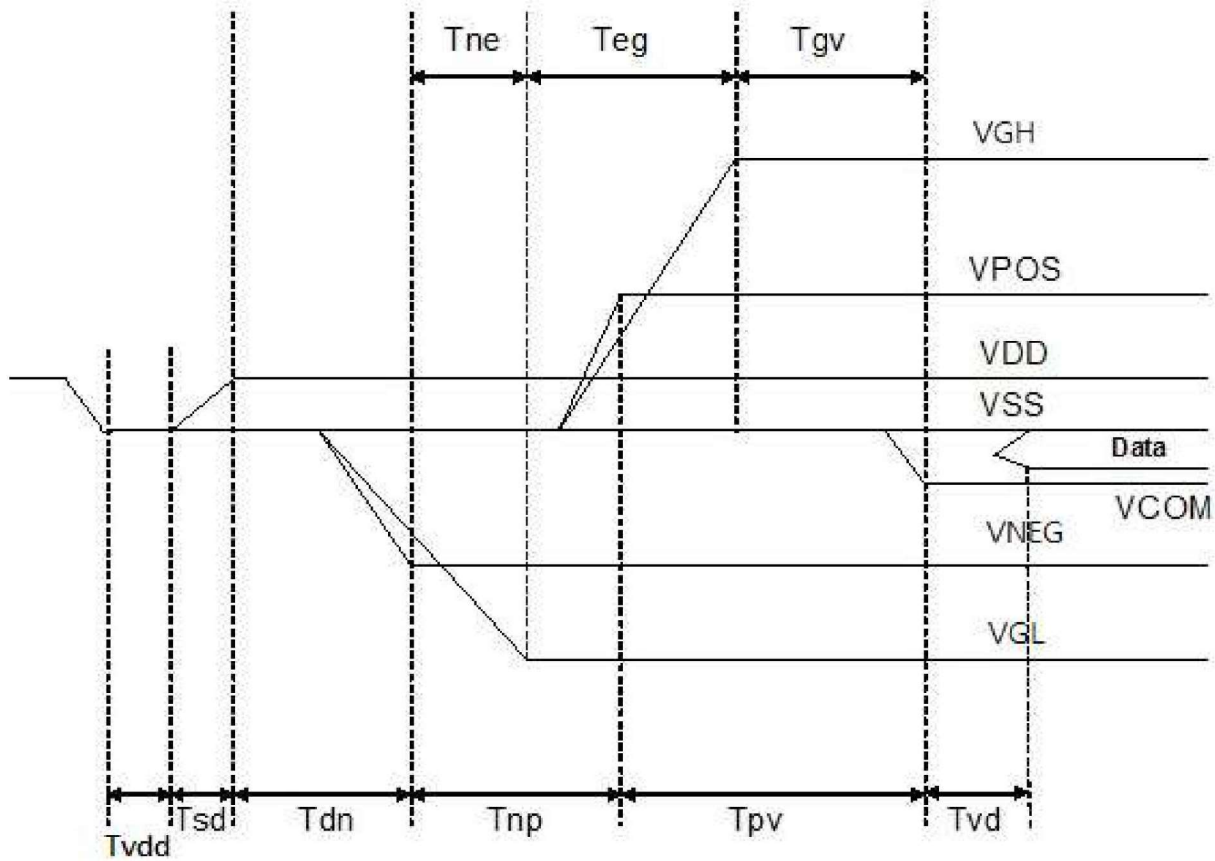

Note: If move from standby mode or power down to power on, VDD voltage must be set GND in the period of 700ms before VDD power on.



	Min	Max
Tsd	30us	20ms
Tdn	100us	-
Tnp	1000us	-
Tpv	100us	-
Tvd	100us	-
Tne	0us	-
Teg	1000us	-
Tgv	100us	-
Tvdd	700ms	-

8. Optical characteristics

8-1) Specifications

Measurements are made with that the illumination is under an angle of 45 degrees, the detector is perpendicular unless otherwise specified.

T = 25°C

Symbol	Parameter	Conditions	Min	Typ.	Max	Unit	Note
R	Reflectance	White	30	35	-	%	Note 8-1
G _n	N _{th} Grey Level	-	-	DS+(WS-DS) ×n/(m-1)	-	L*	-
CR	Contrast Ratio	-	10	12	-		-
T _{update}	Update time	2~4-bit mode 1-bit mode		770 250	-	ms ms	-

WS: White state , DS: Dark state, Gray state from Dark to White :DS 、 G1 、 G2... 、 G_n... 、 G_{m-2} 、 WS
m:4 、 8 、 16 when 2 、 3 、 4 bits mode

Note 8-1: Luminance meter :Eye – One Pro Spectrophotometer.

8-2) Definition of contrast ratio

The contrast ratio (CR) is the ratio between the reflectance in a full white area (R_l) and the reflectance in a dark area (R_d): CR = R_l / R_d

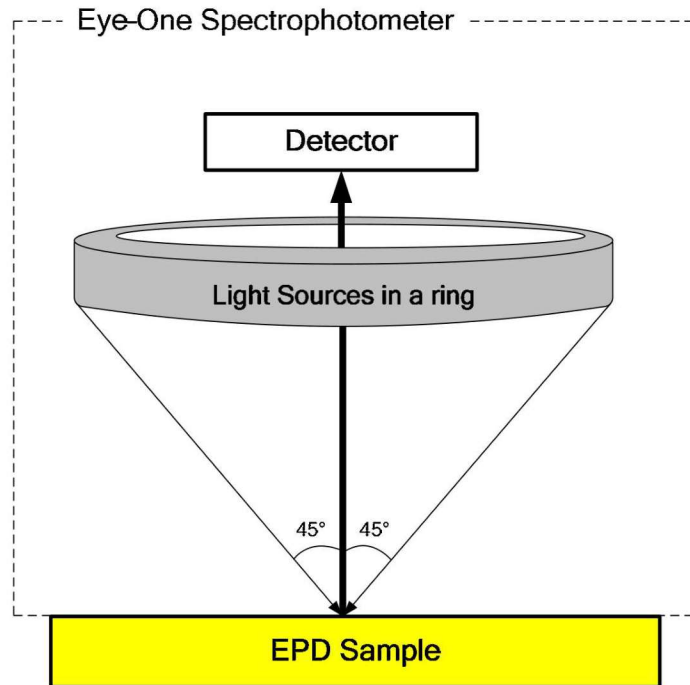

8-3) Reflection Ratio

The reflection ratio is expressed as:

$$R = \text{Reflectance Factor}_{\text{white board}} \times (L_{\text{center}} / L_{\text{white board}})$$

L_{center} is the luminance measured at center in a white area (R=G=B=1). $L_{\text{white board}}$ is the luminance of a standard white board. Both are measured with equivalent illumination source. The viewing angle shall be no more than 2 degrees.

9.HANDLING, SAFETY AND ENVIROMENTAL REQUIREMENTS

WARNING
The display glass may break when it is dropped or bumped on a hard surface. Handle with care. Should the display break, do not touch the electrophoretic material. In case of contact with electrophoretic material, wash with water and soap.
REMARK
All the specifications listed in this document are guaranteed for module only. Post-assembled operation or component(s) may impact module performance or cause unexpected effect or damage and therefore listed specifications is not warranted after any post-assembly operation.

CAUTION
The display module should not be exposed to harmful gases, such as acid and alkali gases, which corrode electronic components.
Disassembling the display module can cause permanent damage and invalidate the warranty agreements.
IPA solvent can only be applied on active area and the back of a glass. For the rest part, it is not allowed.

Mounting Precautions
(1) It's recommended that you consider the mounting structure so that uneven force (ex. Twisted stress) is not applied to the module.
(2) It's recommended that you attach a transparent protective plate to the surface in order to protect the EPD. Transparent protective plate should have sufficient strength in order to resist external force.
(3) You should adopt radiation structure to satisfy the temperature specification.
(4) Acetic acid type and chlorine type materials for the cover case are not desirable because the former generates corrosive gas of attacking the PS at high temperature and the latter causes circuit break by electro-chemical reaction.
(5) Do not touch, push or rub the exposed PS with glass, tweezers or anything harder than HB pencil lead. And please do not rub with dust clothes with chemical treatment. Do not touch the surface of PS for bare hand or greasy cloth. (Some cosmetics deteriorate the PS)
(6) When the surface becomes dusty, please wipe gently with absorbent cotton or other soft materials like chamois soaks with petroleum benzene. Normal-hexane is recommended for cleaning the adhesives used to attach the PS. Do not use acetone, toluene and alcohol because they cause chemical damage to the PS.
(7) Wipe off saliva or water drops as soon as possible. Their long time contact with PS causes deformations and color fading.

Data sheet status	
Product specification	This data sheet contains formal product specifications.
Limiting values	
1.Limiting values given are in accordance with the Absolute Maximum Rating System (IEC 134). Stress above one or more of the limiting values may cause permanent damage to the device. These are stress ratings only and operation of the device at these or at any other conditions above those given in the Characteristics sections of the specification is not implied. Exposure to limiting values for extended periods may affect device reliability.	
2. The LED maximum driving current is 25mA	
Application information	
Where application information is given, it is advisory and does not form part of the specification.	

10. Reliability test

	TEST	CONDITION	METHOD	REMARK
1	High-Temperature Operation	T = +50°C, RH = 30% for 240 hrs	IEC 60 068-2-2Bp	--
2	Low-Temperature Operation	T = 0°C for 240 hrs	IEC 60 068-2-2Ab	--
3	Low-Temperature Storage	T = -25°C for 240 hrs Test in white pattern	IEC 60 068-2-1Ab	--
4	High-Temperature, High-Humidity Operation	T = +40°C, RH = 90% for 168 hrs	IEC 60 068-2-3CA	--
5	High-Temperature Storage	T = +70°C, RH = 23% for 240 hrs	IEC 60 068-2-2Bp	
6	High-Temperature, High-Humidity Storage	T = +60°C, RH = 80% for 240 hrs	IEC 60 068-2-3CA	
7	Temperature Cycle	-25°C → +70°C, 100 Cycles 30min 30min Test in white pattern	IEC 60 068-2-14	--
8	Solar radiation test	765 W/m ² for 168hrs, 40°C Test in white pattern	IEC60 068-2-5Sa	--
9	Package Vibration	1.04G, Frequency: 10~500Hz Direction: X,Y,Z Duration: 1 hours in each direction	Full packed for shipment	--
10	Package Drop Impact	Drop from height of 122 cm on concrete surface. Drop sequence: 1 corner, 3 edges, 6 faces One drop for each.	Full packed for shipment	--
11	Electrostatic Effect (non-operating)	(Machine model)+/- 250V 0Ω, 200pF	IEC 62179, IEC 62180	--
12	Stylus Tapping	POLYACETAL Pen: Top R:0.8mm Load: 300gf Speed: 30 times/min Total 13,500times	--	--

Actual EMC level to be measured on customer application

Note: The protective film must be removed before temperature test.

< Criteria >

In the standard conditions, there is not display function NG issue occurred. (including : line defect ,no image). All the cosmetic specification is judged before the reliability stress.

11. Bar Code definition

EEQ 00 6 01 1 I 7 4 00361 A T
 1 2 3 4 2 5 6 2 7 2 8

1 : EPD model code:

GDEP133UT1: EEQ

2 : Internal control codes:

3 : FPL reversion code

V220C:6 V220E:8

4 : FPL batch code:

01~99	001~099	G0~G9	160~169	Q0~Q9	230~239	X0~X9	300~309
A0~A9	100~109	H0~H9	170~179	R0~R9	240~249	Y0~Y9	310~319
B0~B9	110~119	J0~J9	180~189	S0~S9	250~259	Z0~Z9	320~329
C0~C9	120~129	K0~K9	190~199	T0~T9	260~269		
D0~D9	130~139	L0~L9	200~209	U0~U9	270~279		
E0~E9	140~149	M0~M9	210~219	V0~V9	280~289		
F0~F9	150~159	N0~N9	220~229	W0~W9	290~299		

5 : Year:

N: 2013 / P: 2014 / Q: 2015 / R: 2016 /... / Z: 2024

6 : Month:

1:Jan. 2:Feb. ... 9:Sep. A:Oct. B:Nov. C:Dec.

7 : Serial number

00000-99999

8 : MFG code:

FAB1: K, FAB2: Y, FAB3: T, FAB4: L, FAB5: G,
 Hsinchu: P

12. Border definition

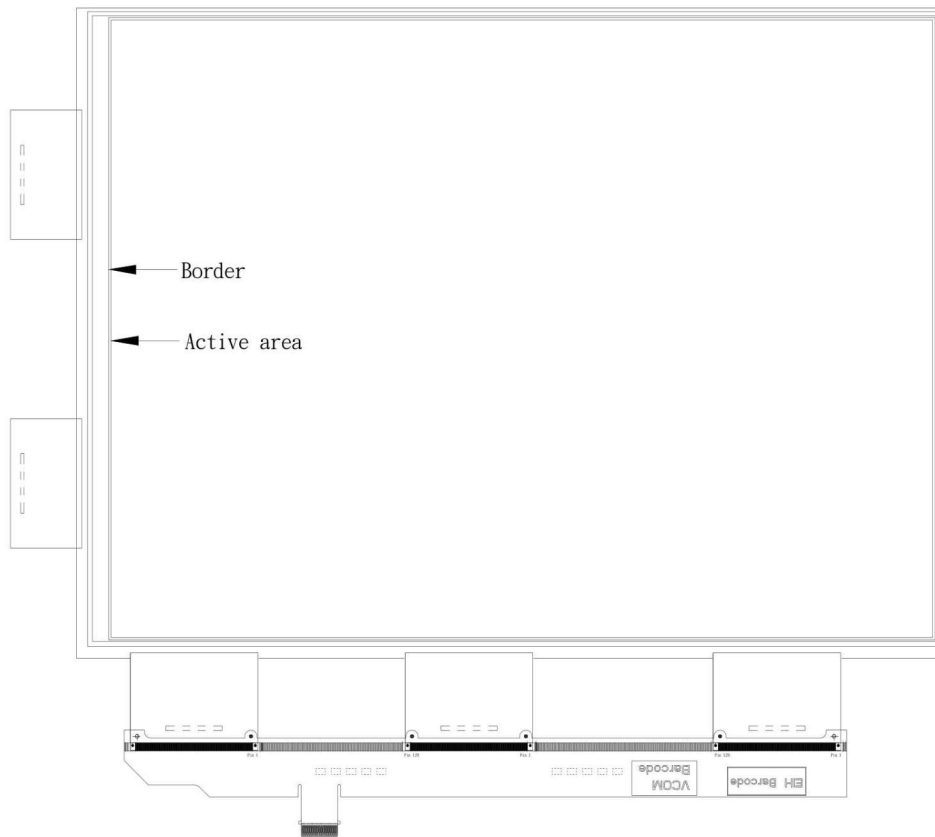

13. Block Diagram

