



**SPECIFICATION
FOR
LCD Module
KD024C-4**

MODULE:	KD024C-4
CUSTOMER:	

REV	DESCRIPTION	DATE
1.0	FIRST ISSUE	2014.06.20
1.1	SECOND ISSUE	2015.12.21

STARTEK	INITIAL	DATE
PREPARED BY		
CHECKED BY		
APPROVED BY		

CUSTOMER	INITIAL	DATE
APPROVED BY		

Part. No	KD024C-4	REV	V1.1	Page 1 of 28
-----------------	-----------------	------------	-------------	---------------------

常备库存
Standing Stock

长期供货
Long Time supply

支持小量
NO MOQ

品种齐全
In Full Range



Contents

General Description	4
1. Block Diagram	5
2. Outline dimension	6
3. Input Terminal Pin Assignment	7
4. LCD Optical Characteristics	9
5. Electrical Characteristics	12
6. AC Characteristic	13
7. LCD Module Out-Going Quality Level	20
8. Reliability Test Result	26
9. Cautions and Handling Precautions	27
10. Packing	28

Part. No	KD024C-4	REV	V1.1	Page 3 of 28
	常备库存 Standing Stock	长期供货 Long Time supply	支持小量 NO MOQ	品种齐全 In Full Range



General Description

* Description

This is a color active matrix TFT (Thin Film Transistor) LCD (liquid crystal display) that uses amorphous silicon TFT as a switching device. This model is composed of a Transmissive type TFT-LCD Panel, driver circuit, back-light unit. The resolution of a 2.4'TFT-LCD contains 240x320 pixels, and can display up to 262K colors.

* Features

-Low Input Voltage: 3.3V(TYP)

-Display Colors of TFT LCD: 65K/262Kcolors

-RGB Interface: 8/9/16/18Bit MCU;3/4SPI+16/18Bit RGB

General Information Items	Specification	Unit	Note
	Main Panel		
Display area(AA)	36.72(H)*48.96(V) (2.4inch)	mm	-
Driver element	TFT active matrix	-	-
Display colors	65/262K	colors	-
Number of pixels	240(RGB)*320	dots	-
Pixel arrangement	RGB vertical stripe	-	-
Pixel pitch	0.153(H)*0.153(V)	mm	-
Viewing angle	6:00	o'clock	-
Controller IC	ST7789V	-	-
Display mode	Transmissive/ Normally White	-	-
Operating temperature	-20~+70	°C	-
Storage temperature	-30~+80	°C	-

* Mechanical Information

Item		Min.	Typ.	Max.	Unit	Note
Module size	Horizontal(H)		42.72		mm	-
	Vertical(V)		60.26		mm	-
	Depth(D)		3.8		mm	-
Weight			TBD		g	-

Part. No	KD024C-4	REV	V1.1	Page 4 of 28
----------	----------	-----	------	--------------

常备库存
Standing Stock

长期供货
Long Time supply

支持小量
NO MOQ

品种齐全
In Full Range



1. Block Diagram

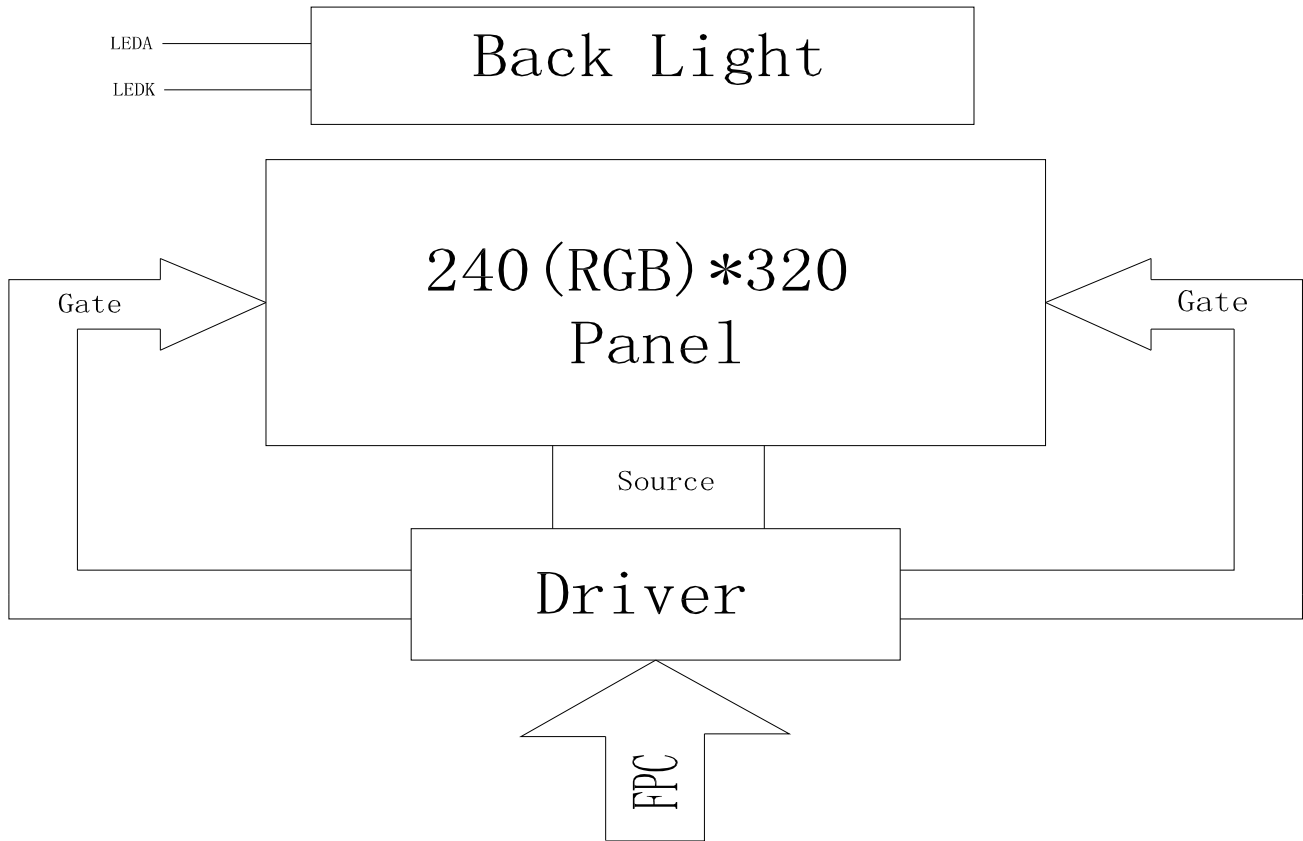

Part. No	KD024C-4	REV	V1.1	Page 5 of 28
	常备库存 Standing Stock	长期供货 Long Time supply	支持小量 NO MOQ	品种齐全 In Full Range



2. Outline dimension

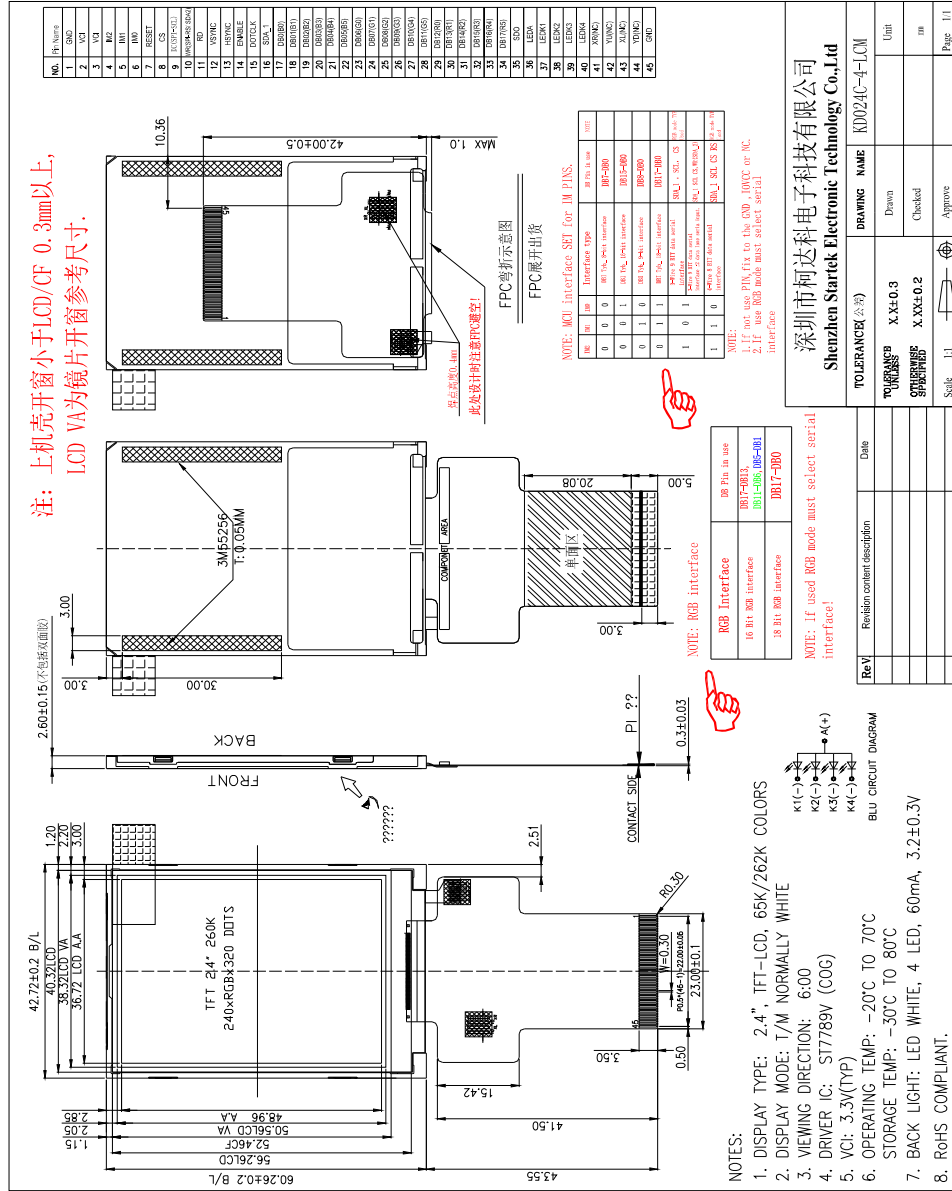

Part. No	KD024C-4	REV	V1.1	Page 6 of 28
----------	----------	-----	------	--------------

常备库存
Standing Stock

长期供货
Long Time supply

支持小量
NO MOQ

品种齐全
In Full Range

**3. Input terminal Pin Assignment**

NO.	SYMBOL	DISCRIPTION	I/O
1	GND	Ground.	P
2	VCI	Supply voltage(3.3V).	P
3	VCI	Supply voltage(3.3V).	P
4	IM2	MPU Parallel interface bus and serial interface select If use RGB Interface must select serial interface. Fix this pin at VCI and GND.	I
5	IM1		I
6	IM0		I
7	RESET	This signal will reset the device and must be applied to properly initialize the chip.	I
8	CS	Chip select input pin ("Low" enable). fix this pin at VCI or GND when not in use.	I
9	DC(SCL)	This pin is used to select "Data or Command" in the parallel interface. When D/CX = '1', data is selected. When D/CX = '0', command is selected. This pin is used serial interface clock in 3-wire 9-bit / 4-wire 8-bit serial data interface. fix this pin at VCI or GND when not in use.	I
10	WR(SPI-RS,SDA2)	The data is applied on the rising edge of the SCL signal. If not used, Second Data lane in 2 data lane serial interface. fix this pin at VCI or GND when not in use.	I
11	RD	Serves as a read signal and MCU read data at the rising edge. fix this pin at VCI or GND when not in use.	I
12	VSYNC	Frame synchronizing signal for RGB interface operation. fix this pin at VCI or GND when not in use.	I
13	HSYNC	Line synchronizing signal for RGB interface operation. fix this pin at VCI or GND when not in use.	I
14	ENABLE	Data enable signal for RGB interface operation. fix this pin at VCI or GND when not in use.	I
15	DOTCLK	Dot clock signal for RGB interface operation. Fix this pin at VCI or GND when not in use.	I
16	SDA1	Data lane in 1 data lane serial interface. The data is latched on the rising edge of the SCL signal.	I
17-34	DB0-DB17	18-bit parallel bi-directional data bus for MCU system and RGB interface mode .	

Part. No	KD024C-4	REV	V1.1	Page 7 of 28
----------	----------	-----	------	--------------

常备库存
Standing Stock

长期供货
Long Time supply

支持小量
NO MOQ

品种齐全
In Full Range



		Fix to GND level when not in use	I/O
35	SDO	SPI interface output pin. -The data is output on the falling edge of the SCL signal. -If not used, let this pin open.	O
36	LEDA	Anode pin of backlight	P
37	LEDK1	Cathode pin OF backlight	P
38	LEDK2	Cathode pin OF backlight	P
39	LEDK3	Cathode pin OF backlight	P
40	LEDK4	Cathode pin OF backlight	P
41	XR	Touch panel Right Glass Terminal	A/D
42	YD	Touch panel Bottom Film Terminal	A/D
43	XL	Touch panel LIFT Glass Terminal	A/D
44	YU	Touch panel Top Film Terminal	A/D
45	GND	Ground.	P

Part. No	KD024C-4	REV	V1.1	Page 8 of 28
----------	----------	-----	------	--------------

常备库存
Standing Stock

长期供货
Long Time supply

支持小量
NO MOQ

品种齐全
In Full Range



4. LCD Optical Characteristics

4.1 Optical specification

Item	Symbol	Conditions	Specifications			Unit	Note
			Min.	Typ.	Max.		
Transmittance	T%	Viewing normal angle $\theta_x = \theta_y = 0^\circ$	4.5	5.0	-	%	All left side data are based on CMI's following condition – 1.LC : TN 2.Light Source :CMI LED BLU 3.Film : 日東 NPF TEG 1465DU 4.Machine : DMS 803
Contrast Ratio	CR		-	500	-		
Response Time (by Quick)	$T_{on} + T_{off}$		-	30	-	ms	
Viewing Angle	Hor.	θ_{x+}	-	45	-	deg.	
		θ_{x-}	-	45	-		
	Ver.	θ_{y+}	-	45	-		
		θ_{y-}	-	20	-		
CF only Color Chromaticity (CIE 1931)	Red	X_R	0.592	0.612	0.632	1.Under C light Simulation 2.NTSC 56%	
		Y_R	0.309	0.329	0.349		
	Green	X_G	0.279	0.299	0.319		
		Y_G	0.547	0.567	0.587		
	Blue	X_B	0.124	0.144	0.164		
		Y_B	0.090	0.110	0.130		
	White	X_W	0.288	0.308	0.328		
		Y_W	0.305	0.325	0.345		

*Note (1) Definition of Contrast Ratio (CR):

The contrast ratio can be calculated by the following expression.

$$\text{Contrast Ratio (CR)} = L63 / L0$$

L63: Luminance of gray level 63

L0: Luminance of gray level 0

$$CR = CR(5)$$

CR (X) is corresponding to the Contrast Ratio of the point X at Figure in Note (5).

Part. No	KD024C-4	REV	V1.1	Page 9 of 28
----------	----------	-----	------	--------------

常备库存
Standing Stock

长期供货
Long Time supply

支持小量
NO MOQ

品种齐全
In Full Range



*Note (2) Definition of Response Time (T_{on} , T_{off}):

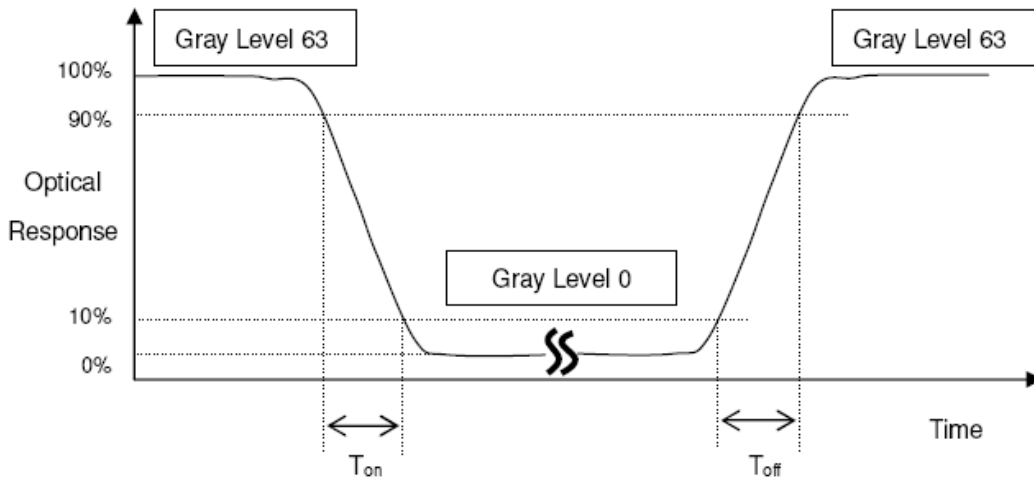

*Note (3) Definition of Viewing Angle

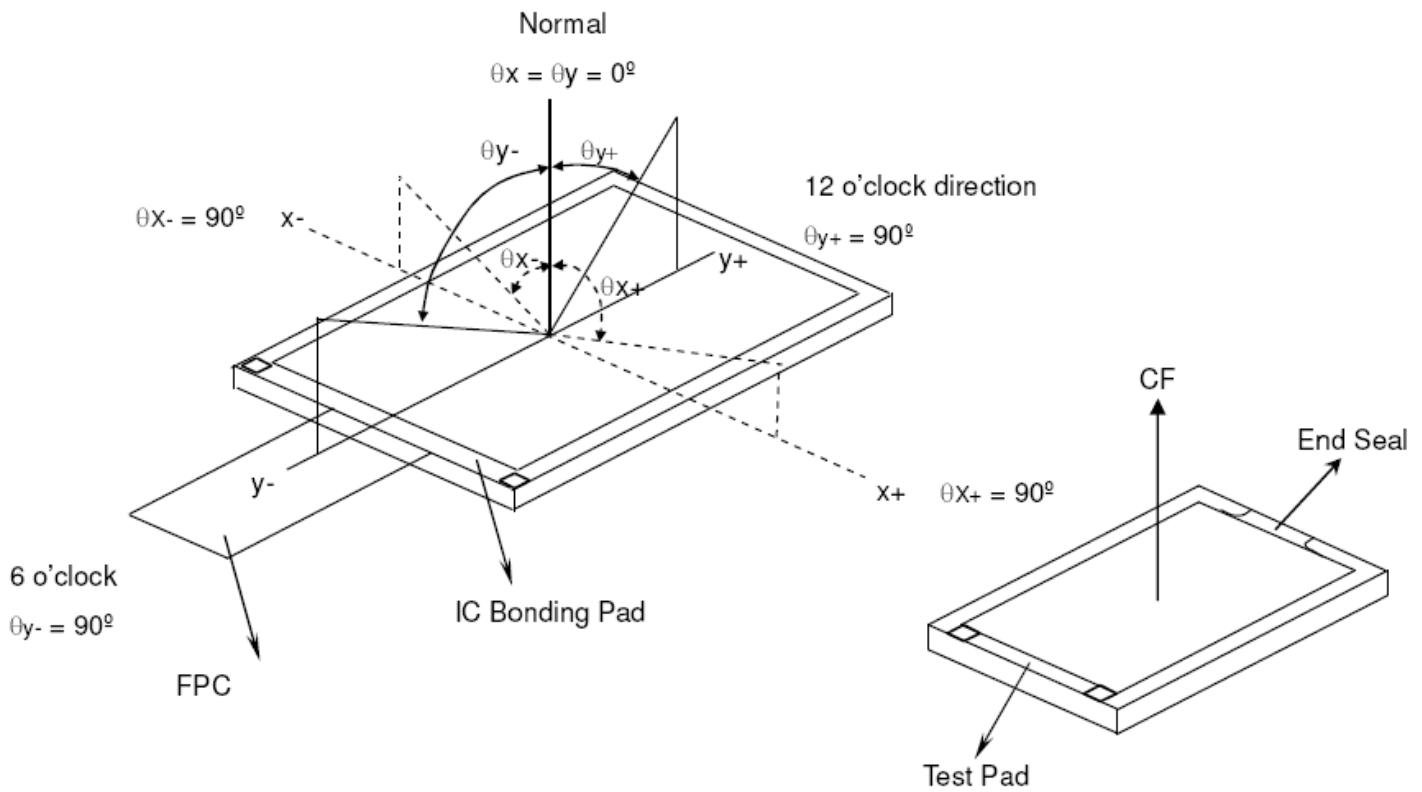

Part. No	KD024C-4	REV	V1.1	Page 10 of 28
	常备库存 Standing Stock	长期供货 Long Time supply	支持小量 NO MOQ	品种齐全 In Full Range



*Note (4) Measurement Set-Up:

The LCD module should be stabilized at a given temperature for 20 minutes to avoid abrupt temperature change during measuring. In order to stabilize the luminance, the measurement should be executed after lighting Backlight for 20 minutes in a windless room.

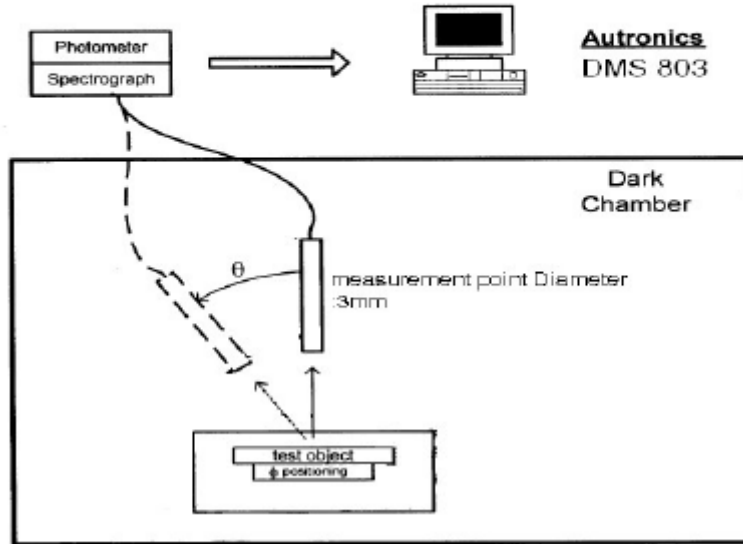

*Note (5)

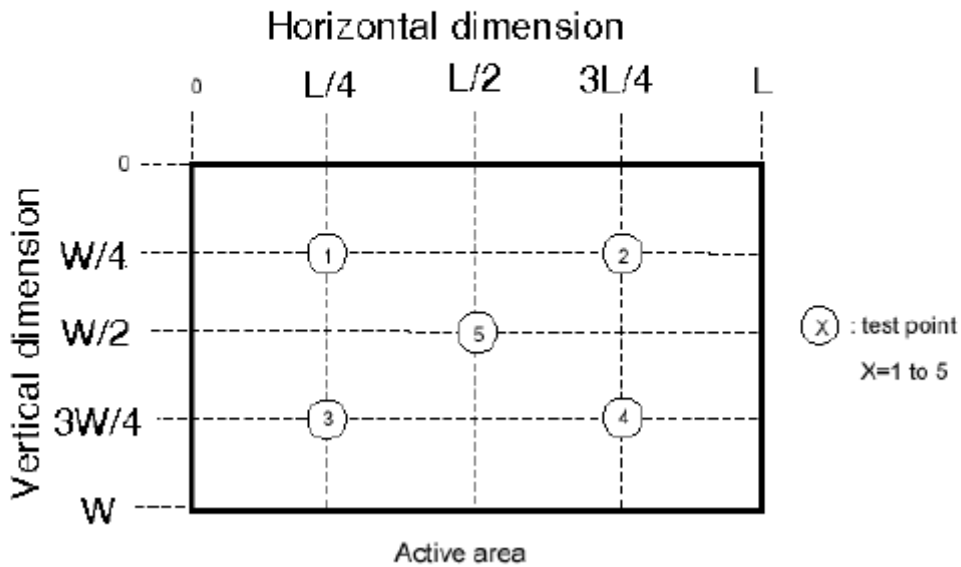

Part. No	KD024C-4	REV	V1.1	Page 11 of 28
----------	----------	-----	------	---------------

常备库存
Standing Stock

长期供货
Long Time supply

支持小量
NO MOQ

品种齐全
In Full Range



5. Electrical Characteristics

5.1 Absolute Maximum Rating (Ta=25 VSS=0V)

Characteristics	Symbol	Min.	Max.	Unit
Digital Supply Voltage	VDD	-0.3	4.6	V
Digital interface supply Voltage	VDDIO	-0.3	4.6	V
Operating temperature	T _{OP}	-20	+70	°C
Storage temperature	T _{ST}	-30	+80	°C

5.2 DC Electrical Characteristics

Characteristics	Symbol	Min.	Typ.	Max.	Unit	Note
Digital Supply Voltage	VDD	2.4	3.3	4.2	V	
Digital interface supply Voltage	VDDIO	1.65	3.3	4.2	V	
Normal mode Current consumption	IDD	--	8	--	mA	
Level input voltage	V _{IH}	0.7V _{DDIO}		V _{DDIO}	V	
	V _{IL}	GND		0.3V _{DDIO}	V	
Level output voltage	V _{OH}	0.8V _{DDIO}		V _{DDIO}	V	
	V _{OL}	GND		0.2V _{DDIO}	V	

5.3 LED Backlight Characteristics

The back-light system is edge-lighting type with 4chips White LED

Item	Symbol	Min.	Typ.	Max.	Unit	Note
Forward Current	I _F	60	80	--	mA	
Forward Voltage	V _F	--	3.2	--	V	
LCM Luminance	L _V	300	--	--	cd/m ²	IF=80MA
Uniformity	AV _g	80	--	--	%	

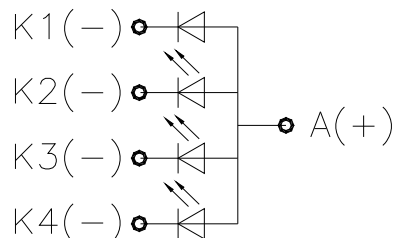

BLU CIRCUIT DIAGRAM

Part. No	KD024C-4	REV	V1.1	Page 12 of 28
----------	----------	-----	------	---------------

常备库存
Standing Stock

长期供货
Long Time supply

支持小量
NO MOQ

品种齐全
In Full Range



6. AC Characteristic

6.1. Display Parallel 18/16/9/8-bit Interface Timing Characteristics (8080- I system)

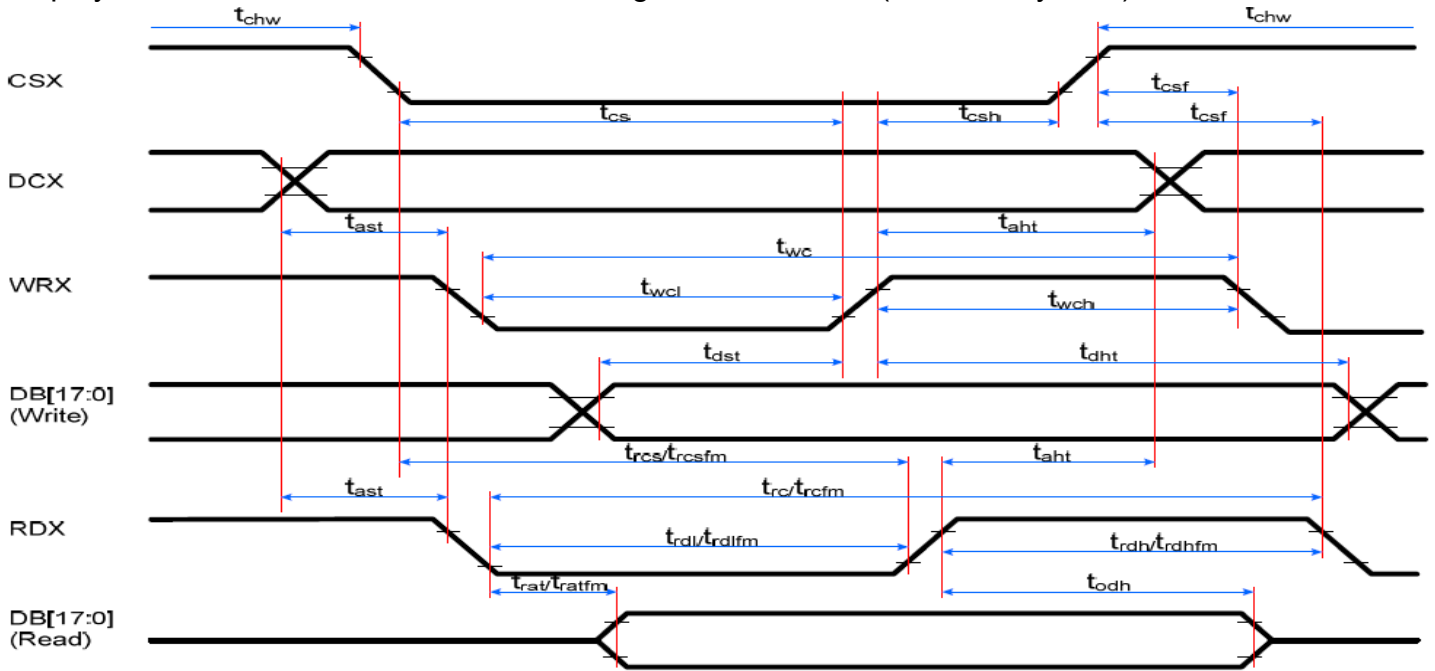

Signal	Symbol	Parameter	min	max	Unit	Description
DCX	t _{ast}	Address setup time	0	-	ns	
	t _{aht}	Address hold time (Write/Read)	10	-	ns	
CSX	t _{chw}	CSX "H" pulse width	0	-	ns	
	t _{cs}	Chip Select setup time (Write)	15	-	ns	
	t _{r_{cs}}	Chip Select setup time (Read ID)	45	-	ns	
	t _{r_{csfm}}	Chip Select setup time (Read FM)	355	-	ns	
	t _{csf}	Chip Select Wait time (Write/Read)	10	-	ns	
WRX	t _{wc}	Write cycle	66	-	ns	
	t _{wrh}	Write Control pulse H duration	15	-	ns	
	t _{wrl}	Write Control pulse L duration	15	-	ns	
RDX (FM)	t _{r_{cfm}}	Read Cycle (FM)	450	-	ns	
	t _{r_{dhfm}}	Read Control H duration (FM)	90	-	ns	
	t _{r_{dlfm}}	Read Control L duration (FM)	355	-	ns	
RDX (ID)	t _{rc}	Read cycle (ID)	160	-	ns	
	t _{r_{dh}}	Read Control pulse H duration	90	-	ns	
	t _{r_{dl}}	Read Control pulse L duration	45	-	ns	
D[17:0], D[15:0], D[8:0], D[7:0]	t _{d_{st}}	Write data setup time	10	-	ns	For maximum CL=30pF For minimum CL=8pF
	t _{d_{ht}}	Write data hold time	10	-	ns	
	t _{r_{at}}	Read access time	-	40	ns	
	t _{r_{atfm}}	Read access time	-	340	ns	
	t _{r_{od}}	Read output disable time	20	80	ns	

Note: $T_a = -30$ to 70 °C, $IOVCC=1.65V$ to $2.8V$, $V_{CI}=2.6V$ to $3.3V$, $GND=0V$

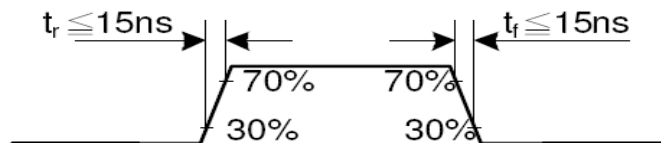

Part. No	KD024C-4	REV	V1.1	Page 13 of 28
	常备库存 Standing Stock	长期供货 Long Time supply	支持小量 NO MOQ	品种齐全 In Full Range



CSX timings :

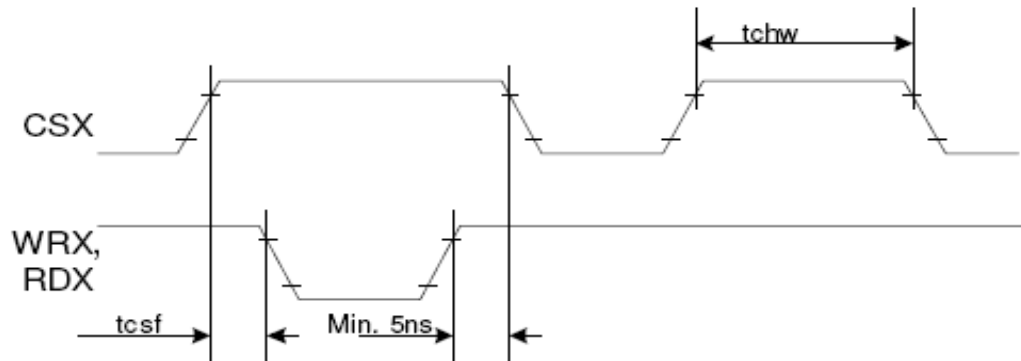

Note: Logic high and low levels are specified as 30% and 70% of IOVCC for Input signals.

Write to read or read to write timings:

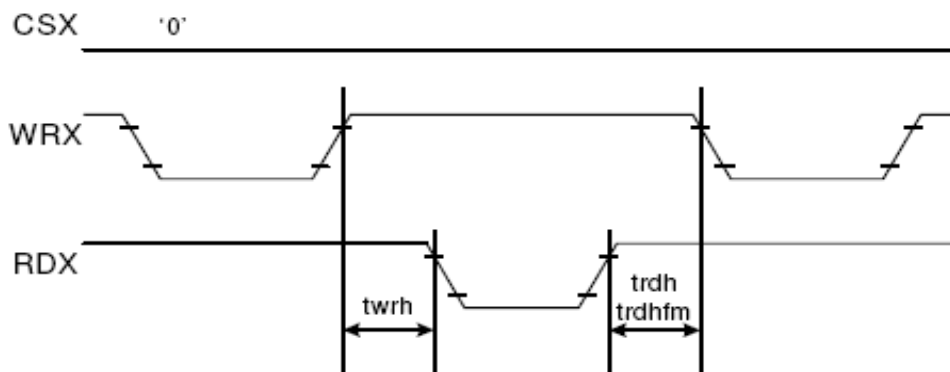

Note: Logic high and low levels are specified as 30% and 70% of IOVCC for Input signals.

Part. No	KD024C-4	REV	V1.1	Page 14 of 28
----------	----------	-----	------	---------------

常备库存
Standing Stock

长期供货
Long Time supply

支持小量
NO MOQ

品种齐全
In Full Range



6.2 Display Serial Interface Timing Characteristics (3-line SPI system)

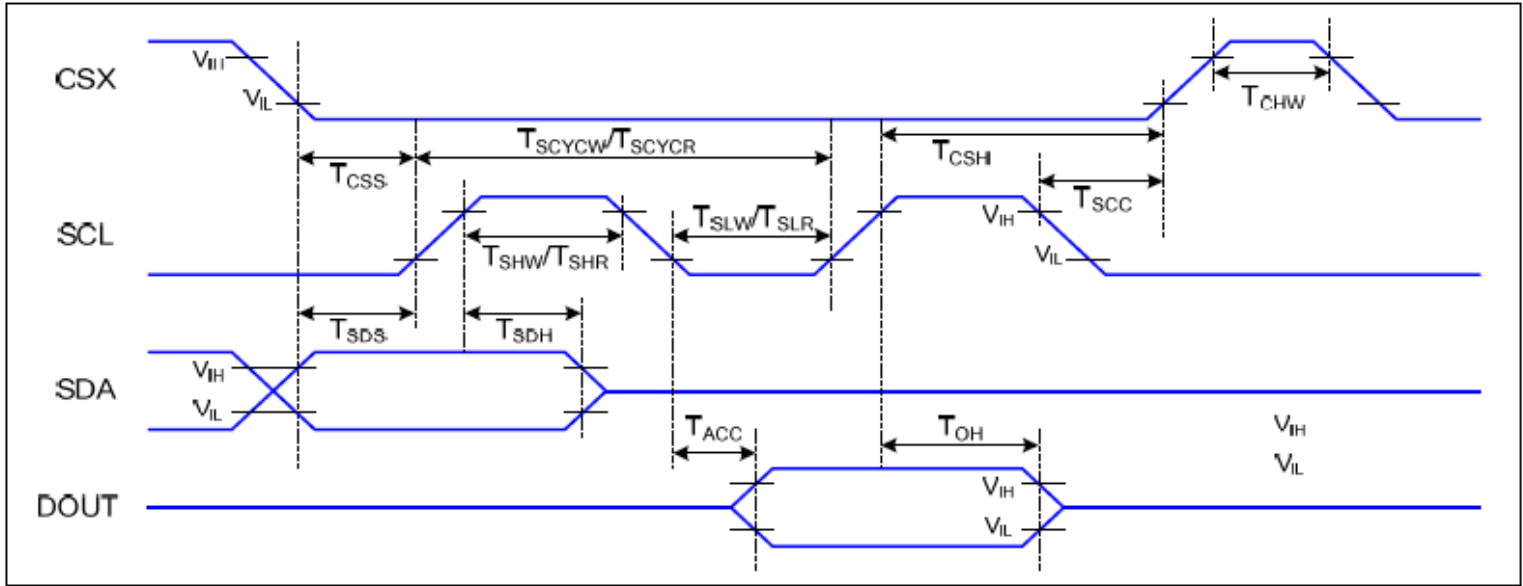

VDDI=1.65 to 3.3V, VDD=2.4 to 3.3V, AGND=DGND=0V, Ta=-30 to 70 °C

Signal	Symbol	Parameter	Min	Max	Unit	Description
CSX	T _{CSS}	Chip select setup time (write)	15		ns	
	T _{CSH}	Chip select hold time (write)	15		ns	
	T _{CSS}	Chip select setup time (read)	60		ns	
	T _{SCC}	Chip select hold time (read)	65		ns	
	T _{CHW}	Chip select "H" pulse width	40		ns	
SCL	T _{SCYCW}	Serial clock cycle (Write)	66		ns	
	T _{SHW}	SCL "H" pulse width (Write)	15		ns	
	T _{SLW}	SCL "L" pulse width (Write)	15		ns	
	T _{SCYCR}	Serial clock cycle (Read)	150		ns	
	T _{SHR}	SCL "H" pulse width (Read)	60		ns	
	T _{SLR}	SCL "L" pulse width (Read)	60		ns	
SDA (DIN)	T _{SDS}	Data setup time	10		ns	
	T _{SDH}	Data hold time	10		ns	
DOUT	T _{ACC}	Access time	10	50	ns	For maximum CL=30pF
	T _{OH}	Output disable time	15	50	ns	For minimum CL=8pF



6.3 Display Serial Interface Timing Characteristics (4-line SPI system)

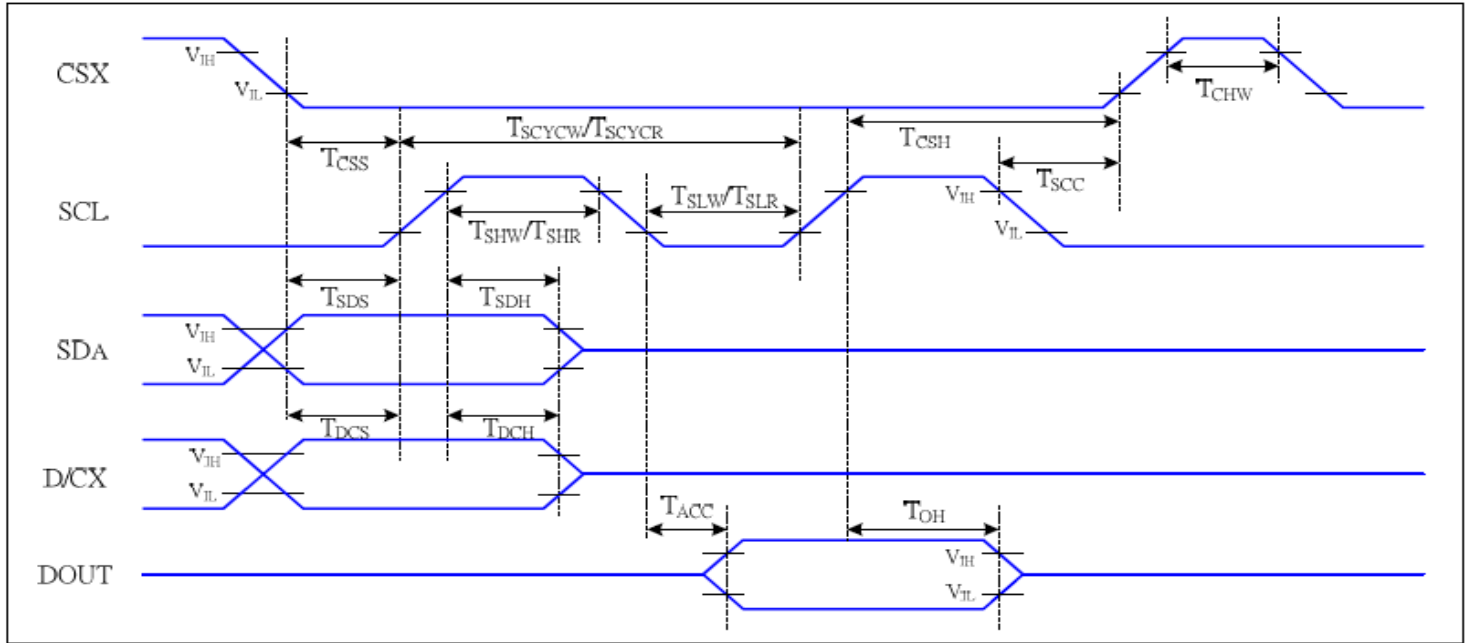

VDDI=1.65 to 3.3V, VDD=2.4 to 3.3V, AGND=DGND=0V, Ta=-30 to 70 °C

Signal	Symbol	Parameter	MIN	MAX	Unit	Description
CSX	T_{CSS}	Chip select setup time (write)	15		ns	
	T_{CSH}	Chip select hold time (write)	15		ns	
	T_{CSS}	Chip select setup time (read)	60		ns	
	T_{SCC}	Chip select hold time (read)	65		ns	
	T_{CHW}	Chip select "H" pulse width	40		ns	
SCL	T_{SCYCW}	Serial clock cycle (Write)	66		ns	-write command & data ram
	T_{SHW}	SCL "H" pulse width (Write)	15		ns	
	T_{SLW}	SCL "L" pulse width (Write)	15		ns	
	T_{SCYCR}	Serial clock cycle (Read)	150		ns	-read command & data ram
	T_{SHR}	SCL "H" pulse width (Read)	60		ns	
	T_{SLR}	SCL "L" pulse width (Read)	60		ns	
D/CX	T_{DCS}	D/CX setup time	10		ns	
	T_{DCH}	D/CX hold time	10		ns	
SDA (DIN)	T_{SDS}	Data setup time	10		ns	
	T_{SDH}	Data hold time	10		ns	
DOUT	T_{ACC}	Access time	10	50	ns	For maximum CL=30pF
	T_{OH}	Output disable time	15	50	ns	For minimum CL=8pF



6.4 Parallel RGB Interface Timing Characteristics

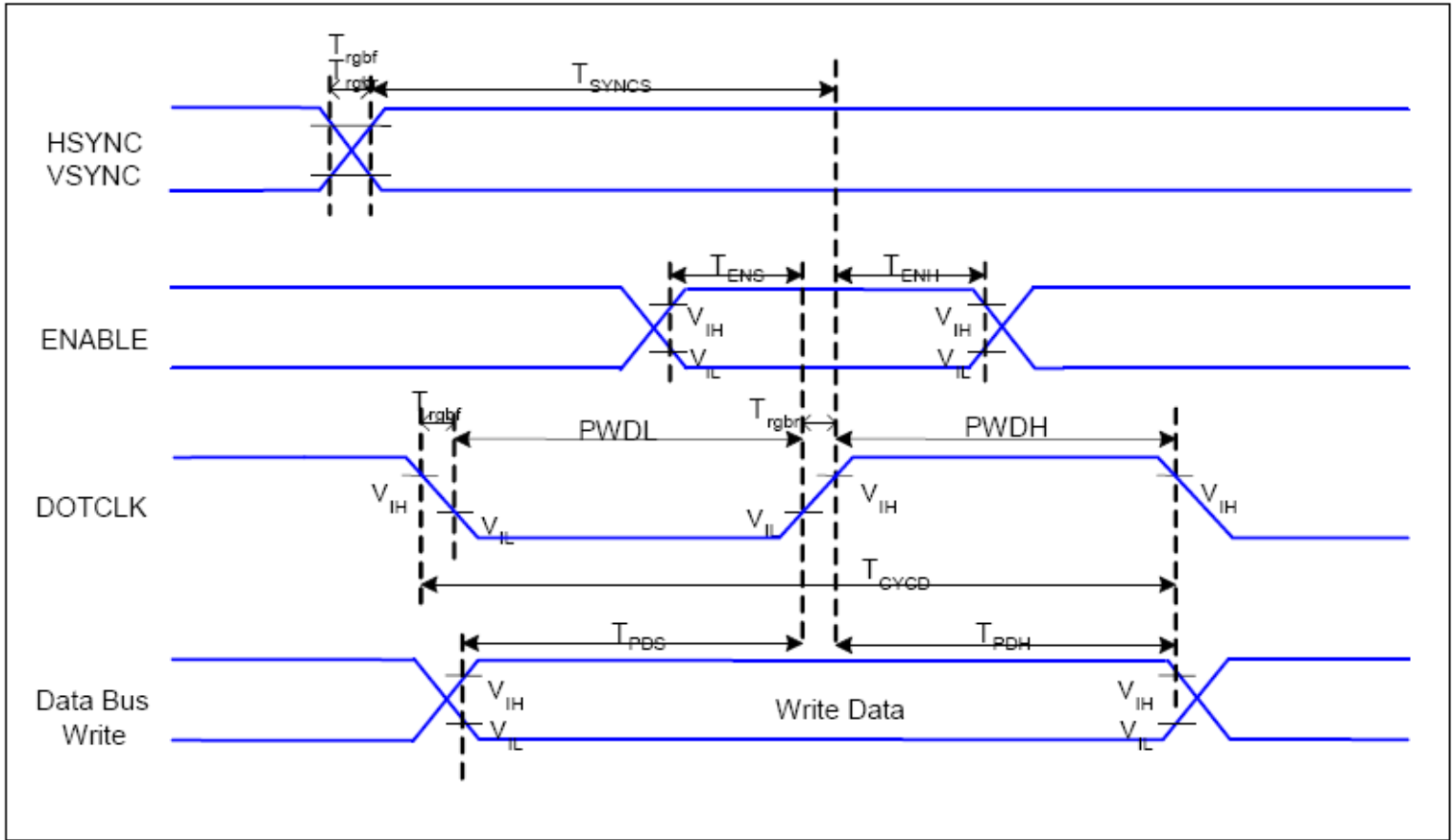

VDD1=1.65 to 3.3V, VDD=2.4 to 3.3V, AGND=DGND=0V, Ta=-30 ~ 70 °C

Signal	Symbol	Parameter	MIN	MAX	Unit	Description
HSYNC, VSYNC	T_{SYNCS}	VSYNC, HSYNC Setup Time	30	-	ns	
ENABLE	T_{ENS}	Enable Setup Time	25	-	ns	
	T_{ENH}	Enable Hold Time	25	-	ns	
DOTCLK	PWDH	DOTCLK High-level Pulse Width	60	-	ns	
	PWDL	DOTCLK Low-level Pulse Width	60	-	ns	
	T_{CYCD}	DOTCLK Cycle Time	120	-	ns	
	Trghr, Trghf	DOTCLK Rise/Fall time	-	20	ns	
DB	T_{PDS}	PD Data Setup Time	50	-	ns	
	T_{PDH}	PD Data Hold Time	50	-	ns	



6.5 Reset Timing Characteristics

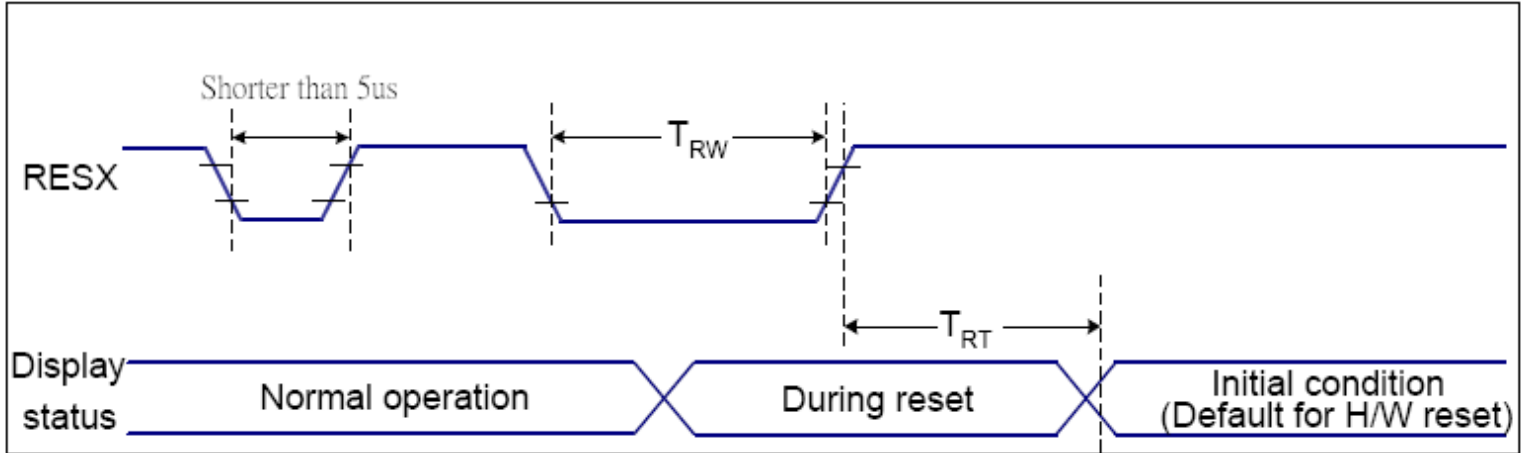

$V_{DD1}=1.65$ to $3.3V$, $V_{DD}=2.4$ to $3.3V$, $AGND=DGND=0V$, $T_a=-30 \sim 70 \text{ } ^\circ\text{C}$

Related Pins	Symbol	Parameter	MIN	MAX	Unit
RESX	TRW	Reset pulse duration	10	-	us
	TRT	Reset cancel	-	5 (Note 1, 5)	ms
				120 (Note 1, 6, 7)	ms

Notes:

1. The reset cancel includes also required time for loading ID bytes, VCOM setting and other settings from NVM (or similar device) to registers. This loading is done every time when there is HW reset cancel time (t_{RT}) within 5 ms after a rising edge of RESX.

2. Spike due to an electrostatic discharge on RESX line does not cause irregular system reset according to the table below:

RESX Pulse	Action
Shorter than 5us	Reset Rejected
Longer than 9us	Reset
Between 5us and 9us	Reset starts

3. During the Resetting period, the display will be blanked (The display is entering blanking sequence, which maximum time is 120 ms, when Reset Starts in Sleep Out –mode. The display remains the blank state in Sleep In –mode.) and then return to Default condition for Hardware Reset.

4. Spike Rejection also applies during a valid reset pulse as shown below:

Part. No	KD024C-4	REV	V1.1	Page 18 of 28
----------	----------	-----	------	---------------

常备库存
Standing Stock

长期供货
Long Time supply

支持小量
NO MOQ

品种齐全
In Full Range

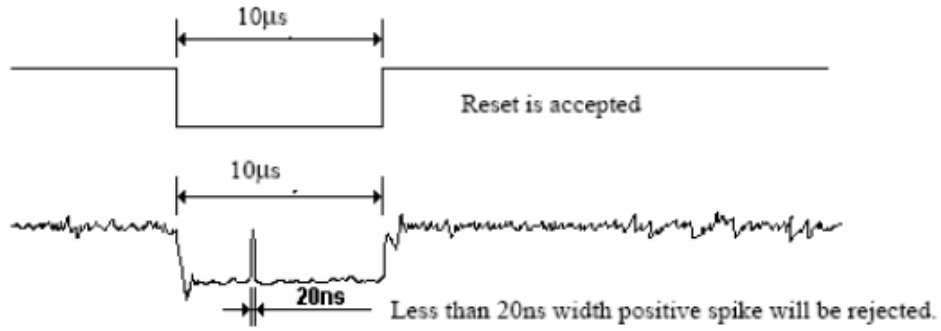

5. When Reset applied during Sleep In Mode.

6. When Reset applied during Sleep Out Mode.

7. It is necessary to wait 5msec after releasing RESX before sending commands. Also Sleep Out command cannot be sent for 120msec.

Part. No	KD024C-4	REV	V1.1	Page 19 of 28
----------	----------	-----	------	---------------

常备库存
Standing Stock

长期供货
Long Time supply

支持小量
NO MOQ

品种齐全
In Full Range



7. LCD Module Out-Going Quality Level

7.1 VISUAL & FUNCTION INSPECTION STANDARD

7.1.1 Inspection conditions

Inspection performed under the following conditions is recommended.

Temperature : 25±5℃

Humidity : 65%±10%RH

Viewing Angle : Normal viewing Angle.

Illumination: Single fluorescent lamp (300 to 700Lux)

Viewing distance:30-50cm

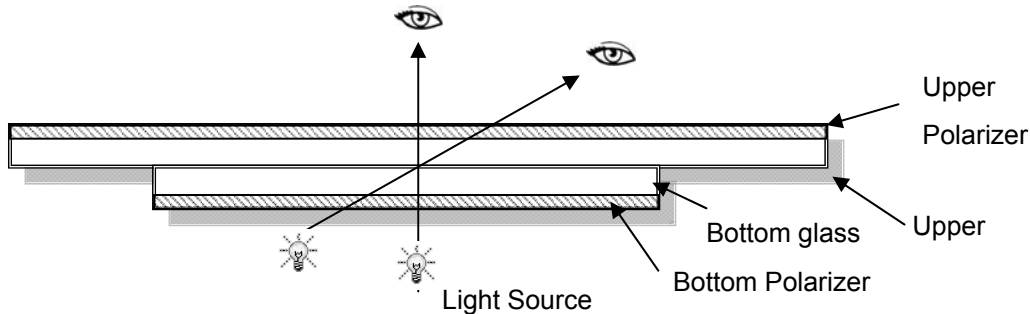

7.1.2 Definition

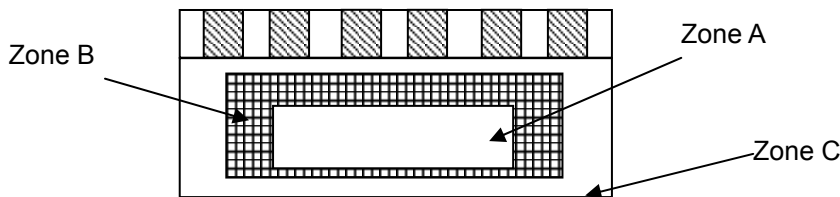

Zone A : Effective Viewing Area(Character or Digit can be seen)

Zone B : Viewing Area except Zone A

Zone C : Outside (Zone A+Zone B) which can not be seen after assembly by customer .)

Note:

As a general rule ,visual defects in Zone C can be ignored when it doesn't effect product function or appearance after assembly by customer.

7.1.3 Sampling Plan

Part. No	KD024C-4	REV	V1.1	Page 20 of 28
	常备库存 Standing Stock	长期供货 Long Time supply	支持小量 NO MOQ	品种齐全 In Full Range



According to GB/T 2828-2003 ; , normal inspection, Class II

AQL:

Major defect	Minor defect
0.65	1.5

LCD: Liquid Crystal Display , TP: Touch Panel , LCM: Liquid Crystal Module

No	Items to be inspected	Criteria	Classification of defects
1	Functional defects	1) No display, Open or miss line 2) Display abnormally, Short 3) Backlight no lighting, abnormal lighting. 4) TP no function	Major
2	Missing	Missing component	
3	Outline dimension	Overall outline dimension beyond the drawing is not allowed	
4	Color tone	Color unevenness, refer to limited sample	Minor
5	Soldering appearance	Good soldering , Peeling off is not allowed.	
6	LCD/Polarizer/TP	Black/White spot/line, scratch, crack, etc.	



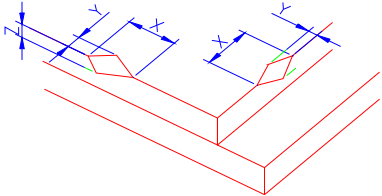
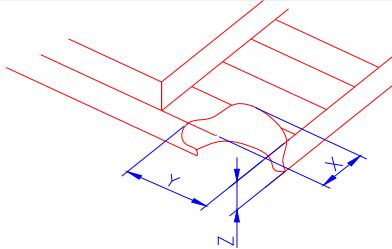
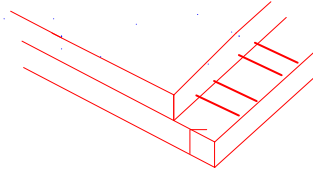

7.1.4 Criteria (Visual)

Number	Items	Criteria(mm)						
1.0 LCD Crack/Broken NOTE: X: Length Y: Width Z: Height L: Length of ITO, T: Height of LCD	(1) The edge of LCD broken	 <table border="1" data-bbox="868 640 1441 792"> <tr> <td>X</td> <td>Y</td> <td>Z</td> </tr> <tr> <td>≤3.0mm</td> <td><Inner border line of the seal</td> <td>≤T</td> </tr> </table>	X	Y	Z	≤3.0mm	<Inner border line of the seal	≤T
X	Y	Z						
≤3.0mm	<Inner border line of the seal	≤T						
	(2)LCD corner broken	 <table border="1" data-bbox="932 1128 1377 1229"> <tr> <td>X</td> <td>Y</td> <td>Z</td> </tr> <tr> <td>≤3.0mm</td> <td>≤L</td> <td>≤T</td> </tr> </table>	X	Y	Z	≤3.0mm	≤L	≤T
X	Y	Z						
≤3.0mm	≤L	≤T						
	(3) LCD crack	 <p style="text-align: center;">Crack Not allowed</p>						

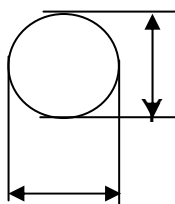

2.0	Spot defect	① light dot (LCD/TP/Polarizer black/white spot , light dot, pinhole, dent, stain)																												
	 <p>X</p> <p>$\Phi=(X+Y)/2$</p>	<table border="1"> <thead> <tr> <th rowspan="2">Zone Size (mm)</th> <th colspan="3">Acceptable Qty</th> </tr> <tr> <th>A</th> <th>B</th> <th>C</th> </tr> </thead> <tbody> <tr> <td>$\Phi \leq 0.10$</td> <td colspan="3">Ignore</td> </tr> <tr> <td>$0.10 < \Phi \leq 0.20$</td> <td colspan="3">3(distance $\geq 10\text{mm}$)</td> </tr> <tr> <td>$0.20 < \Phi \leq 0.25$</td> <td colspan="3">2</td> </tr> <tr> <td>$\Phi > 0.25$</td> <td colspan="3">0</td> </tr> </tbody> </table>	Zone Size (mm)	Acceptable Qty			A	B	C	$\Phi \leq 0.10$	Ignore			$0.10 < \Phi \leq 0.20$	3(distance $\geq 10\text{mm}$)			$0.20 < \Phi \leq 0.25$	2			$\Phi > 0.25$	0							
Zone Size (mm)	Acceptable Qty																													
	A	B	C																											
$\Phi \leq 0.10$	Ignore																													
$0.10 < \Phi \leq 0.20$	3(distance $\geq 10\text{mm}$)																													
$0.20 < \Phi \leq 0.25$	2																													
$\Phi > 0.25$	0																													
		② Dim spot (LCD/TP/Polarizer dim dot, light leakage, dark spot)																												
		<table border="1"> <thead> <tr> <th rowspan="2">Zone Size (mm)</th> <th colspan="3">Acceptable Qty</th> </tr> <tr> <th>A</th> <th>B</th> <th>C</th> </tr> </thead> <tbody> <tr> <td>$\Phi \leq 0.1$</td> <td colspan="3">Ignore</td> </tr> <tr> <td>$0.10 < \Phi \leq 0.20$</td> <td colspan="3">3(distance $\geq 10\text{mm}$)</td> </tr> <tr> <td>$0.20 < \Phi \leq 0.30$</td> <td colspan="3">2</td> </tr> <tr> <td>$\Phi > 0.30$</td> <td colspan="3">0</td> </tr> </tbody> </table>	Zone Size (mm)	Acceptable Qty			A	B	C	$\Phi \leq 0.1$	Ignore			$0.10 < \Phi \leq 0.20$	3(distance $\geq 10\text{mm}$)			$0.20 < \Phi \leq 0.30$	2			$\Phi > 0.30$	0							
Zone Size (mm)	Acceptable Qty																													
	A	B	C																											
$\Phi \leq 0.1$	Ignore																													
$0.10 < \Phi \leq 0.20$	3(distance $\geq 10\text{mm}$)																													
$0.20 < \Phi \leq 0.30$	2																													
$\Phi > 0.30$	0																													
		③ Polarizer accidented spot																												
		<table border="1"> <thead> <tr> <th rowspan="2">Zone Size (mm)</th> <th colspan="3">Acceptable Qty</th> </tr> <tr> <th>A</th> <th>B</th> <th>C</th> </tr> </thead> <tbody> <tr> <td>$\Phi \leq 0.2$</td> <td colspan="3">Ignore</td> </tr> <tr> <td>$0.3 < \Phi \leq 0.5$</td> <td colspan="3">2(distance $\geq 10\text{mm}$)</td> </tr> <tr> <td>$\Phi > 0.5$</td> <td colspan="3">0</td> </tr> </tbody> </table>	Zone Size (mm)	Acceptable Qty			A	B	C	$\Phi \leq 0.2$	Ignore			$0.3 < \Phi \leq 0.5$	2(distance $\geq 10\text{mm}$)			$\Phi > 0.5$	0											
Zone Size (mm)	Acceptable Qty																													
	A	B	C																											
$\Phi \leq 0.2$	Ignore																													
$0.3 < \Phi \leq 0.5$	2(distance $\geq 10\text{mm}$)																													
$\Phi > 0.5$	0																													
	Line defect (LCD/TP /Polarizer black/white line, scratch, stain)	<table border="1"> <thead> <tr> <th rowspan="2">Width(mm)</th> <th rowspan="2">Length(mm)</th> <th colspan="3">Acceptable Qty</th> </tr> <tr> <th>A</th> <th>B</th> <th>C</th> </tr> </thead> <tbody> <tr> <td>$\Phi \leq 0.03$</td> <td>Ignore</td> <td colspan="3">Ignore</td> </tr> <tr> <td>$0.03 < W \leq 0.05$</td> <td>$L \leq 3.0$</td> <td colspan="3">$N \leq 2$</td> </tr> <tr> <td>$0.05 < W \leq 0.08$</td> <td>$L \leq 2.0$</td> <td colspan="3">$N \leq 2$</td> </tr> <tr> <td>$0.08 < W$</td> <td colspan="4">Define as spot defect</td> </tr> </tbody> </table>	Width(mm)	Length(mm)	Acceptable Qty			A	B	C	$\Phi \leq 0.03$	Ignore	Ignore			$0.03 < W \leq 0.05$	$L \leq 3.0$	$N \leq 2$			$0.05 < W \leq 0.08$	$L \leq 2.0$	$N \leq 2$			$0.08 < W$	Define as spot defect			
Width(mm)	Length(mm)	Acceptable Qty																												
		A	B	C																										
$\Phi \leq 0.03$	Ignore	Ignore																												
$0.03 < W \leq 0.05$	$L \leq 3.0$	$N \leq 2$																												
$0.05 < W \leq 0.08$	$L \leq 2.0$	$N \leq 2$																												
$0.08 < W$	Define as spot defect																													



3.0	Polarizer Bubble	<table border="1"> <tr> <th rowspan="2">Zone Size (mm)</th> <th colspan="3">Acceptable Qty</th> </tr> <tr> <th>A</th> <th>B</th> <th>C</th> </tr> <tr> <td>$\Phi \leq 0.2$</td> <td colspan="2">Ignore</td> <td rowspan="4">Ignore</td> </tr> <tr> <td>$0.2 < \Phi \leq 0.4$</td> <td colspan="2">3 (distance ≥ 10 m)</td> </tr> <tr> <td>$0.4 < \Phi \leq 0.6$</td> <td colspan="2">2</td> </tr> <tr> <td>$0.6 < \Phi$</td> <td colspan="2">0</td> </tr> </table>			Zone Size (mm)	Acceptable Qty			A	B	C	$\Phi \leq 0.2$	Ignore		Ignore	$0.2 < \Phi \leq 0.4$	3 (distance ≥ 10 m)		$0.4 < \Phi \leq 0.6$	2		$0.6 < \Phi$	0		
		Zone Size (mm)	Acceptable Qty																						
			A	B	C																				
		$\Phi \leq 0.2$	Ignore		Ignore																				
		$0.2 < \Phi \leq 0.4$	3 (distance ≥ 10 m)																						
$0.4 < \Phi \leq 0.6$	2																								
$0.6 < \Phi$	0																								
4.0	SMT	According to IPC-A-610C class II standard . Function defect and missing part are major defect ,the others are minor defect.																							
5.0	TP Related	TP bubble/ accidented spot	<table border="1"> <tr> <th rowspan="2">Size Φ(mm)</th> <th colspan="3">Acceptable Qty</th> </tr> <tr> <th>A</th> <th>B</th> <th>C</th> </tr> <tr> <td>$\Phi \leq 0.1$</td> <td colspan="2">Ignore</td> <td rowspan="4">Ignore</td> </tr> <tr> <td>$0.1 < \Phi \leq 0.25$</td> <td colspan="2">3 (distance \geq</td> </tr> <tr> <td>$0.25 < \Phi \leq 0.3$</td> <td colspan="2">2</td> </tr> <tr> <td>$0.3 < \Phi$</td> <td colspan="2">0</td> </tr> </table>			Size Φ (mm)	Acceptable Qty			A	B	C	$\Phi \leq 0.1$	Ignore		Ignore	$0.1 < \Phi \leq 0.25$	3 (distance \geq		$0.25 < \Phi \leq 0.3$	2		$0.3 < \Phi$	0	
			Size Φ (mm)	Acceptable Qty																					
				A	B	C																			
			$\Phi \leq 0.1$	Ignore		Ignore																			
			$0.1 < \Phi \leq 0.25$	3 (distance \geq																					
$0.25 < \Phi \leq 0.3$	2																								
$0.3 < \Phi$	0																								
Assembly deflection	beyond the edge of backlight ≤ 0.15 mm																								
Newton Ring	<p>Newton Ring area $> 1/3$ TP area NG</p> <p>Newton Ring area $\leq 1/3$ TP area OK</p>	  																							

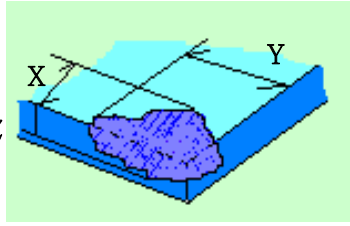
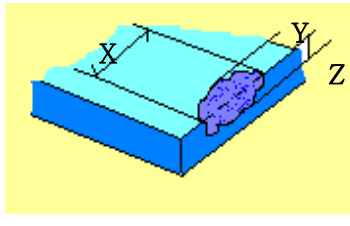

		TP corner broken	<table border="1"> <tr> <td>X</td> <td>Y</td> <td>Z</td> </tr> <tr> <td>$X \leq 3.0\text{mm}$</td> <td>$Y \leq 3.0\text{mm}$</td> <td>$Z < \text{LCD thickness}$</td> </tr> </table>	X	Y	Z	$X \leq 3.0\text{mm}$	$Y \leq 3.0\text{mm}$	$Z < \text{LCD thickness}$	
		X	Y	Z						
$X \leq 3.0\text{mm}$	$Y \leq 3.0\text{mm}$	$Z < \text{LCD thickness}$								
X : length Y : width Z : height	* Circuitry broken is not allowed.									
		TP edge broken	<table border="1"> <tr> <td>X</td> <td>Y</td> <td>Z</td> </tr> <tr> <td>$X \leq 6.0\text{mm}$</td> <td>$Y \leq 2.0\text{mm}$</td> <td>$Z < \text{LCD thickness}$</td> </tr> </table>	X	Y	Z	$X \leq 6.0\text{mm}$	$Y \leq 2.0\text{mm}$	$Z < \text{LCD thickness}$	
		X	Y	Z						
$X \leq 6.0\text{mm}$	$Y \leq 2.0\text{mm}$	$Z < \text{LCD thickness}$								
X : length Y : width Z : height	* Circuitry broken is not allowed.									

Criteria (functional items)

Number	Items	Criteria (mm)
1	No display	Not allowed
2	Missing segment	Not allowed
3	Short	Not allowed
4	Backlight no lighting	Not allowed
5	TP no function	Not allowed



8. Reliability Test Result

8.1 Condition

Item	Condition	Sample Size	Test Result	Note
Low Temperature Operating Life test	-20°C, 96HR	3ea	pass	-
Thermal Humidity Operating Life test	70°C, 90%RH, 96HR	3ea	pass	-
Temperature Cycle ON/OFF test	-20°C ↔ 70°C, ON/OFF, 20CYC	3ea	pass	(1)
High Temperature Storage test	80°C, 96HR	3ea	pass	-
Low Temperature Storage test	- 30°C, 96HR	3ea	pass	-
Thermal Shock Resistance	The sample should be allowed to stand the following 5 cycles of operation: TSTL for 30 minutes -> normal temperature for 5 minutes -> TSTH for 30 minutes -> normal temperature for 5 minutes, as one cycle, then taking it out and drying it at normal temperature, and allowing it stand for 24 hours	3ea	pass	
Box Drop Test	1 Corner 3 Edges 6 faces, 66cm(MEDIUM BOX)	1box	pass	-

Note (1) ON Time over 10 seconds, OFF Time under 10 seconds

Part. No	KD024C-4	REV	V1.1	Page 26 of 28
	常备库存 Standing Stock	长期供货 Long Time supply	支持少量 NO MOQ	品种齐全 In Full Range



9. Cautions and Handling Precautions

9.1 Handling and Operating the Module

(1) When the module is assembled, it should be attached to the system firmly.

Do not warp or twist the module during assembly work.

(2) Protect the module from physical shock or any force. In addition to damage, this may cause improper operation or damage to the module and back-light unit.

(3) Note that polarizer is very fragile and could be easily damaged. Do not press or scratch the surface.

(4) Do not allow drops of water or chemicals to remain on the display surface.

If you have the droplets for a long time, staining and discoloration may occur.

(5) If the surface of the polarizer is dirty, clean it using some absorbent cotton or soft cloth.

(6) The desirable cleaners are water, IPA (Isopropyl Alcohol) or Hexane.

Do not use ketene type materials (ex. Acetone), Ethyl alcohol, Toluene, Ethyl acid or Methyl chloride. It might permanent damage to the polarizer due to chemical reaction.

(7) If the liquid crystal material leaks from the panel, it should be kept away from the eyes or mouth. In case of contact with hands, legs, or clothes, it must be washed away thoroughly with soap.

(8) Protect the module from static; it may cause damage to the CMOS ICs.

(9) Use finger-stalls with soft gloves in order to keep display clean during the incoming inspection and assembly process.

(10) Do not disassemble the module.

(11) Protection film for polarizer on the module shall be slowly peeled off just before use so that the electrostatic charge can be minimized.

(12) Pins of I/F connector shall not be touched directly with bare hands.

(13) Do not connect, disconnect the module in the "Power ON" condition.

(14) Power supply should always be turned on/off by the item 6.1 Power On Sequence & 6.2 Power Off Sequence

9.2 Storage and Transportation.

(1) Do not leave the panel in high temperature, and high humidity for a long time.

It is highly recommended to store the module with temperature from 0 to 35 °C and relative humidity of less than 70%

(2) Do not store the TFT-LCD module in direct sunlight.

(3) The module shall be stored in a dark place. When storing the modules for a long time, be sure to adopt effective measures for protecting the modules from strong ultraviolet radiation, sunlight, or fluorescent light.

(4) It is recommended that the modules should be stored under a condition where no condensation is allowed. Formation of dewdrops may cause an abnormal operation or a failure of the module.

In particular, the greatest possible care should be taken to prevent any module from being operated where condensation has occurred inside.

(5) This panel has its circuitry FPC on the bottom side and should be handled carefully in order not to be stressed.

Part. No	KD024C-4	REV	V1.1	Page 27 of 28
	常备库存 Standing Stock	长期供货 Long Time supply	支持小量 NO MOQ	品种齐全 In Full Range



10.Packing

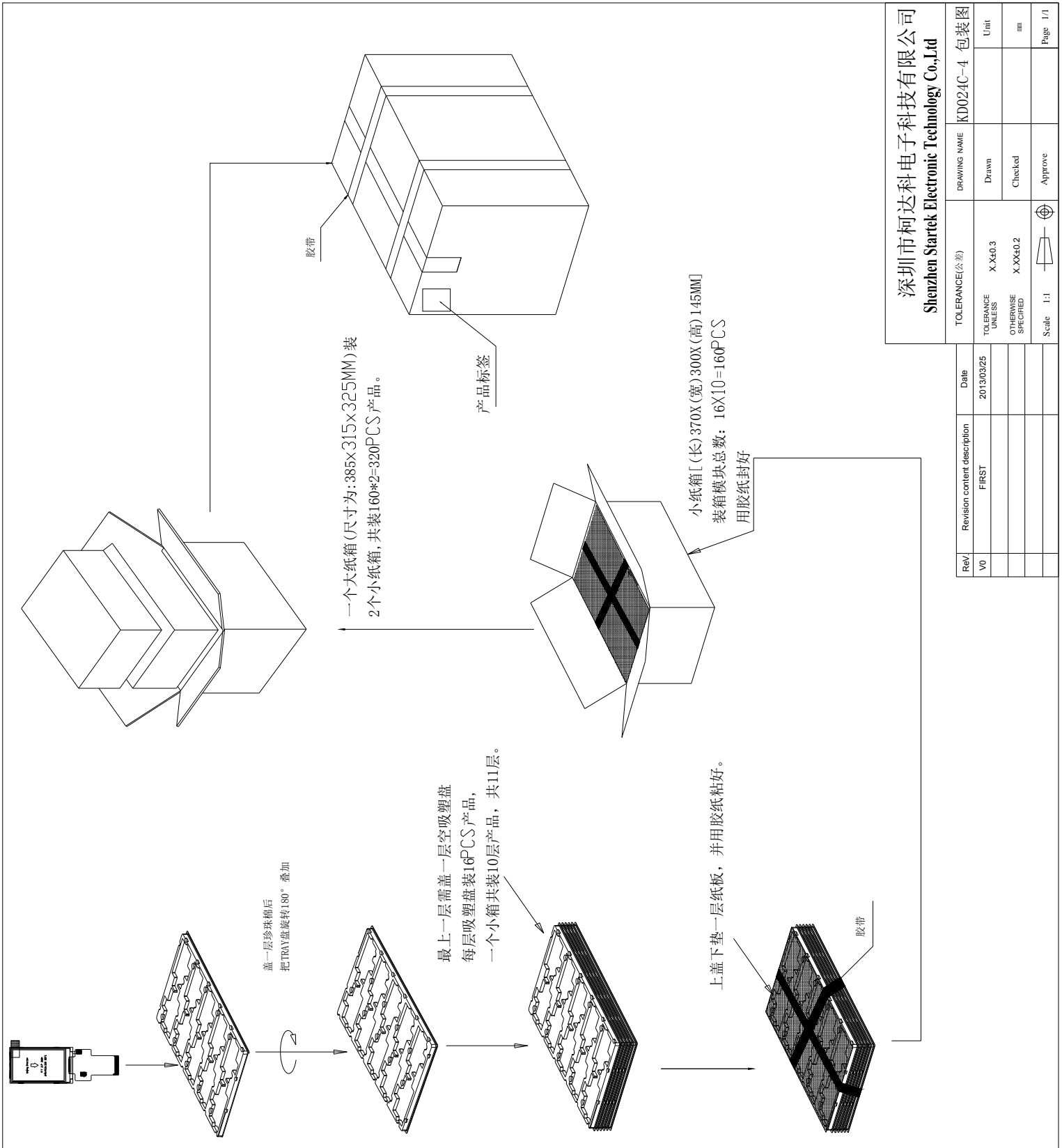

深圳市柯达科电子科技有限公司 Shenzhen Startek Electronic Technology Co., Ltd		DRAWING NAME	KD024C-4 包装图	
TOLERANCE(公差)		Drawn		Unit
TOLERANCE UNLESS OTHERWISE SPECIFIED	X.X40.3	Checked		mm
Scale	1:1	Approve		Page 1/1

Rev	Revision content description	Date
V0	FIRST	2013/03/25

Part. No	KD024C-4	REV	V1.1	Page 28 of 28
----------	----------	-----	------	---------------

常备库存 Standing Stock 长期供货 Long Time supply 支持小量 NO MOQ 品种齐全 In Full Range