

This document is the property of Nian-Yeong Corporation and is delivered on the express condition that it is not to be disclosed, reproduced or used, in whole or in part, for manufacture or sale by anyone other than Nian-Yeong Corporation without its prior consent, and that no right is granted to disclose or to use any information in this document.

CUSTOMER DRAWING

REV.	DESCRIPTION	APPROVED BY	DATE	ECN NO.
A	RELEASE	Emily Suen	08/11/11'	
B				
C				
D				

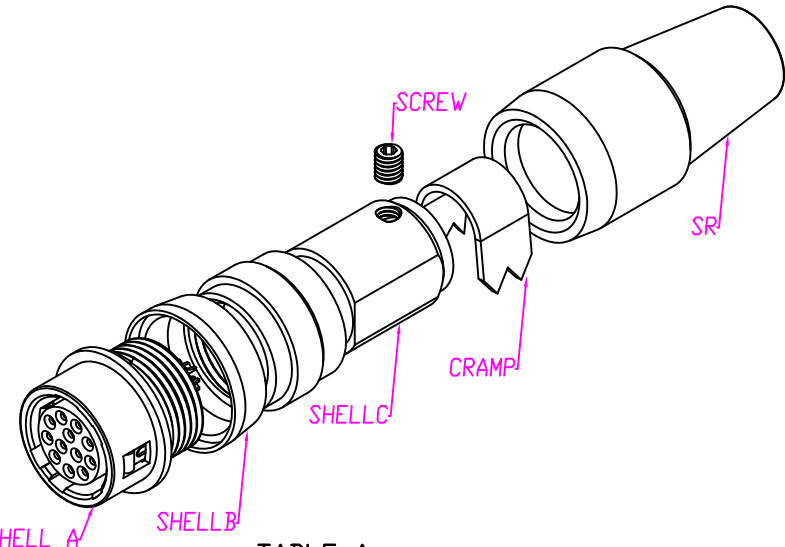
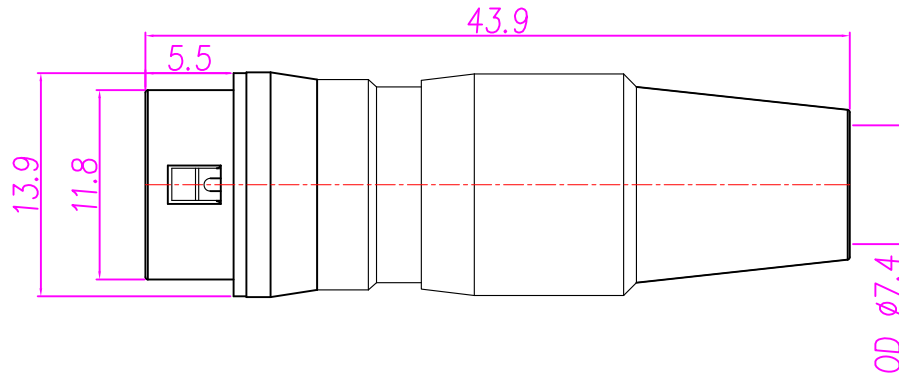
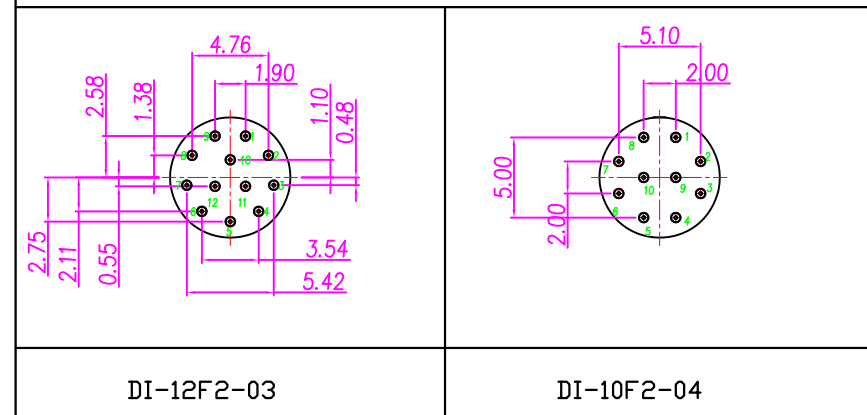

TABLE A

- | | |
|---|---------------------------|
| 1. MATERIAL : | 2. FINISH : |
| 1-1. HOUSING : NYLON46 UL94V-0
COLOR : BLACK | 2-1. CONTACT : GOLD FLASH |
| 1-2. CONTACT : BRASS | 2-2. SHELL A : NICKEL |
| 1-3. SHELL A : ZINC ALLOY | 2-3. SHELL B : NICKEL |
| 1-4. SHELL B : BRASS | 2-4. SHELL C : NICKEL |
| 1-5. SHELL C : BRASS | 2-5. SCREW : NICKEL |
| 1-6. SCREW : ALLOY STEEL | |
| 1-7. CLAMP : BRASS | |
| 1-8. SR : TPR ; COLOR : BLACK | |

CONTACT ARRANGEMENT & DIMENSIONS(FRONT VIEW)



DRAWN	APPVL	UNIT	TOLERANCE	TITLE	SHEET
Emily Suen		mm	.x ±0.20	DIN (F)?????(SHELL TYPE:RECEPTACLE)	1/2
CHK'D		SCALE 1:1	.xx ±0.10	PART NO. SEE TABLE A	VERSION A
			.xxx ±0.05	DWG NO. QC5610	
			.xxxx ±0.03		
			ANGULA ±1°		