

This document is the property of Nian-Yeong Corporation and is delivered on the express condition that it is not to be disclosed, reproduced or used, in whole or in part, for manufacture or sale by anyone other than Nian-Yeong Corporation without its prior consent, and that no right is granted to disclose or to use any information in this document.

# CUSTOMER DRAWING

REV.	DESCRIPTION	APPROVED BY	DATE	ECN NO.
A	RELEASE	Emily Suen	30/12/11'	
B				
C				

## 1. MATERIAL :

- 1-1. HOUSING : NYLON 46 UL94V-0 ; COLOR : BLACK
- 1-2. CONTACT : PHOSPHOR BRONZE
- 1-3. SHELL A : Zinc Alloy
- 1-4. SHELL B : BRASS
- 1-5. O-RING A : NBR; COLOR : BLACK
- 1-6. SCREW : ALLOY STEEL
- 1-7. CLAMP : BRASS
- 1-8. SR : TPR

## 2. FINISH :

- 2-1. CONTACT A : 5 MICRO INCHES MIN. GOLD PLATED
- 2-2. SHELL A : NICKEL PLATED 60u" ~ 100u" OVER ALL
- 2-3. SHELL B : NICKEL PLATED 60u" ~ 100u" OVER ALL
- 2-4. SCREW : NICKEL PLATED 60u" ~ 100u" OVER ALL

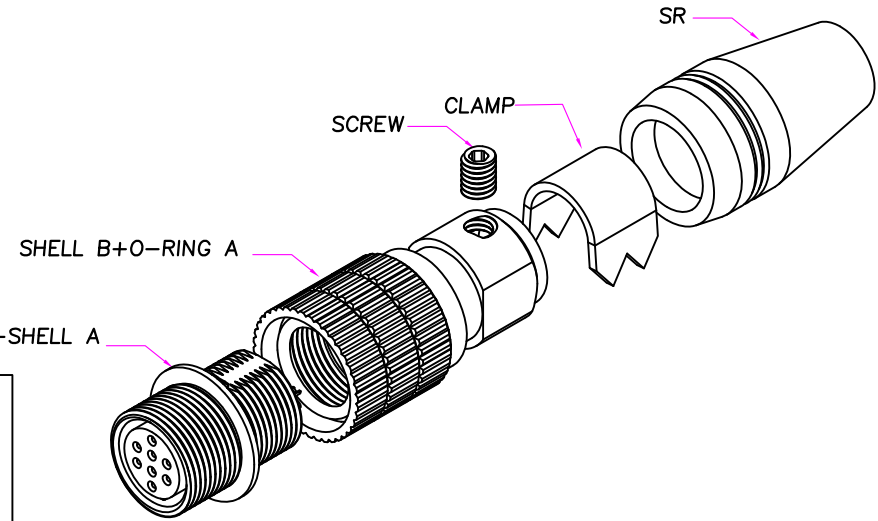
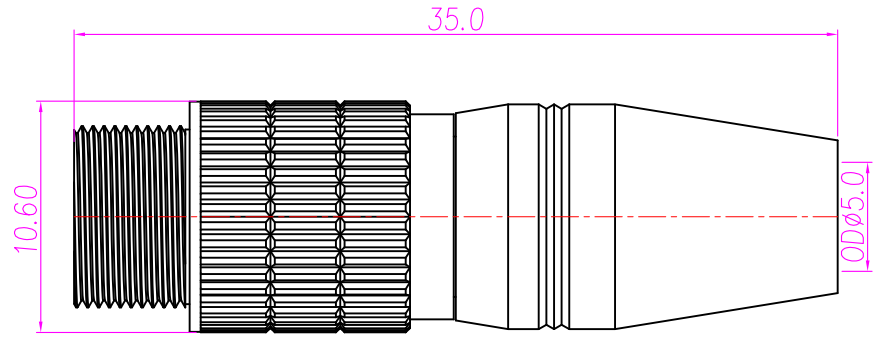
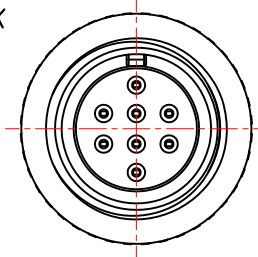

DI-04F2-03(4P)

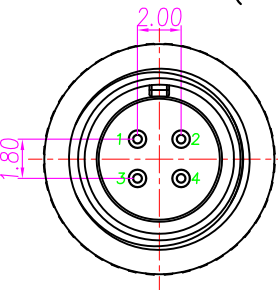

DI-06F2-04(6P)

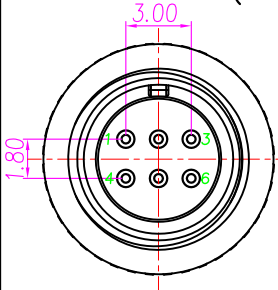

DI-08F2-03(8P)

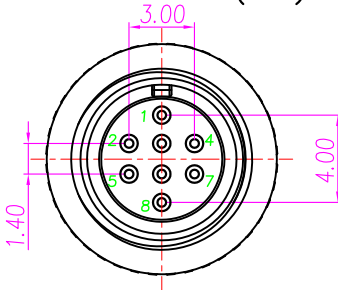

DRAWN	Emily Suen	APP'D	UNIT	mm	TOLERANCE		TITLE	DIN M8*0.5 (F) ?????(SHELL: JACK)			SHEET
CHK'D			SCALE	1:1	.x ±0.20 .xx ±0.10 .xxx ±0.05 .xxxx ±0.03 ANGULA ±1°		PART NO.	SEE TABLE	DWG NO.	QC5631	
ENTERPRISE CO., LTD.							VERSION				A