

This document is the property of Nian-Yeong Corporation and is delivered on the express condition that it is not to be disclosed, reproduced or used, in whole or in part, for manufacture or sale by anyone other than Nian-Yeong Corporation without its prior consent, and that no right is granted to disclose or to use any information in this document.

CUSTOMER DRAWING

REV.	DESCRIPTION	APPROVED BY	DATE	ECN NO.
A	RELEASE	Emily Suen	25/10/11'	
B				
C				
D				

TABLE A

CONTACT ARRANGEMENT(FRONT VIEW)	
WP-03M2-28	WP-06M2-19

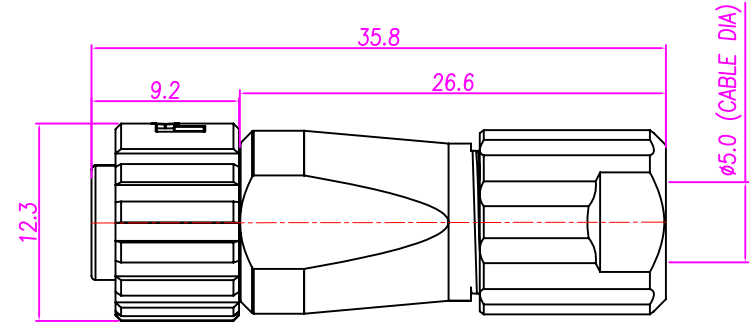

1. MATERIAL :

1-1. HOUSING : PPS UL94V-0
COLOR : BLACK

1-2. CONTACT : BRASS

1-3. PLUG SHELL : ZINC ALLOY

1-4. LOCKING COLLAR : ZINC ALLOY

1-5. SPRING1 : STAINLESS STEEL

1-6. SPRING2 : STAINLESS STEEL

1-7. O-RING 1 : EPDM

1-8. BACK SHELL : ZINC ALLOY

1-9. SHIELDING : PHOSPHOR BRONZE

1-10. O-RING 2 : EPDM

1-11. CLAMP : BRASS

1-12. O-RING 3 : NBR ; COLOR : BLACK

1-13. STRAIN RELIEF COLLAR : NYLON66 UL94V-0 ; COLOR : WHITE

1-14. TIGHTENING COLLAR : PPS ; COLOR : BROWN

2. FINISH :

2-1. CONTACT : GOLD FLASH

2-2. PLUG SHELL : NICKEL

2-3. LOCKING COLLAR : NICKEL

2-4. BACK SHELL : NICKEL

2-5. SHIELDING : NICKEL

2-6. CLAMP : NICKEL

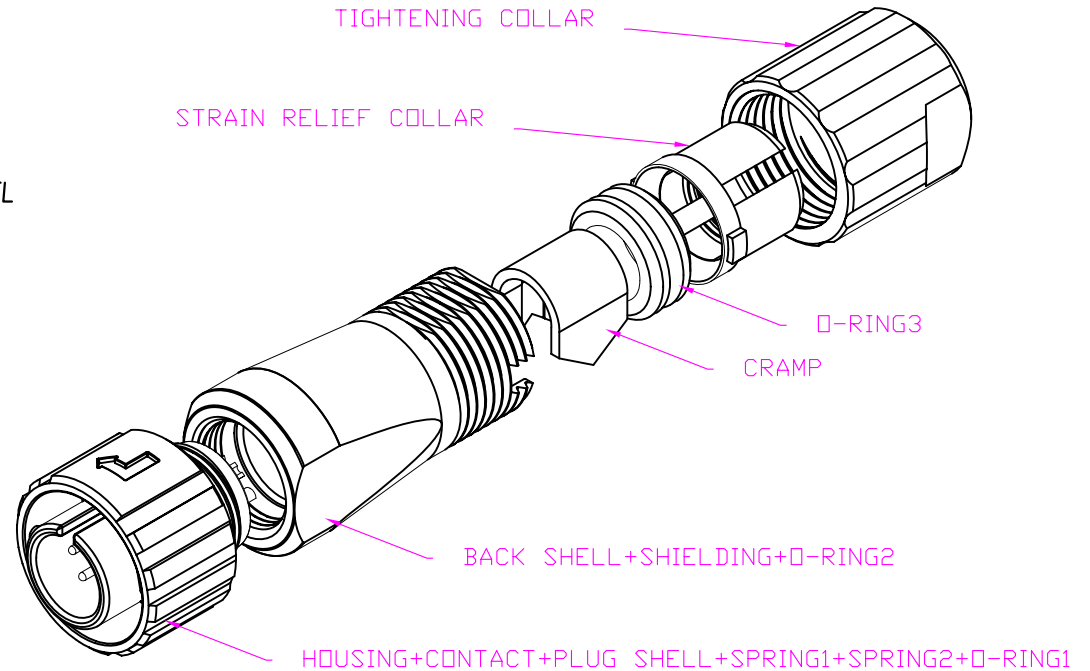

DRAWN	Emily Suen	APPVL	UNIT	mm	TOLERANCE			TITLE	WP (M) 连接器 (PLUG-LF07 TYPE)			SHEET	1/2
CHK'D			SCALE	1:1	.x ±0.20 .xx ±0.10 .xxx ±0.05 .xxxx ±0.03 ANGULA ±1°			PART NO.	SEE TABLE A	DWG NO.	QC5713	VERSION	A

NIAN YEONG
ENTERPRISE CO., LTD.