

## 7-Segment Decoder Driver

**Technology:** PMOS

### Features

- Display numbers from 1 to 16
- Supply voltage  $-V_S = 12\text{ V}$
- Output currents  $-I_{O1}$  to  $-I_{O9} = 10\text{ mA}$
- Input code BCD + 1
- Pull-up resistors  $50\text{ k}\Omega$  to  $V_S$
- Separate input for dark switching

**Case:** 16 pin dual inline plastic

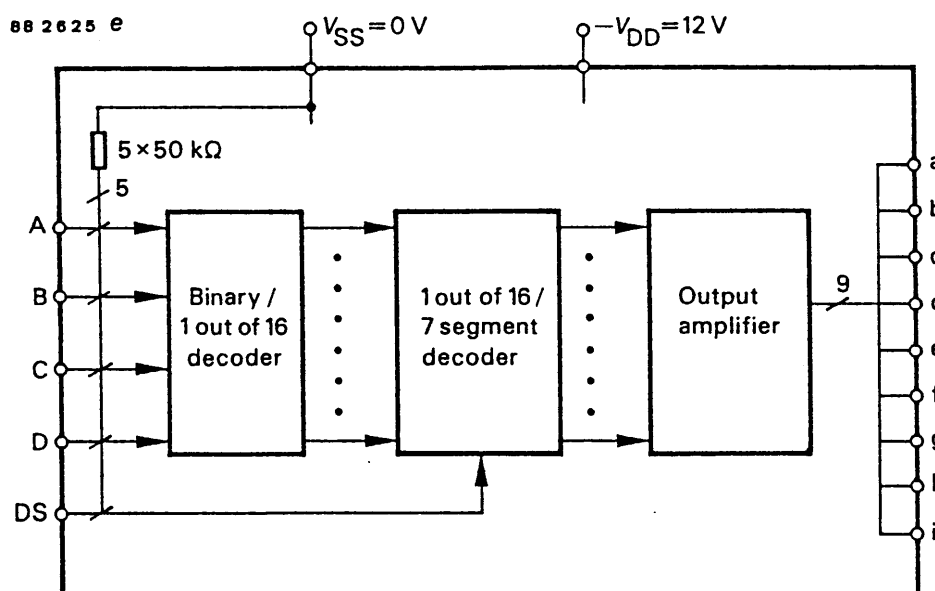

Figure 1. Block diagram

### Absolute Maximum Ratings

Parameters	Symbol	Value	Unit
Supply voltage range Pin 16	$V_S$	-13.5 to +0.3	V
Supply current Pin 1	$I_S$	150	mA
Output current of one output Pin 7 to 15	$-I_{O1}$ to $-I_{O9}$	50	mA
Total power dissipation $-I_{O1}$ to $-I_{O9}$ à 10 mA = 90 mA $-V_{O1}$ to $-V_{O9} = 2\text{ V}$ , $T_{\text{amb}} = 70^\circ\text{C}$	$P_{\text{tot}}$	220	mW

## Electrical Characteristics

$-V_S = 12\text{ V}$ , reference point Pin 1,  $T_{\text{amb}} = 25^\circ\text{C}$ , unless otherwise specified

Parameters	Test Conditions / Pin	Symbol	Min	Typ	Max	Unit
Supply voltage	Pin 16	$-V_S$	10.8	12	13.2	V
Supply quiescent current	Pin 1	$I_{SB}$			1.5	mA
Output reverse current	$-V_0 = 13.2\text{ V}$ , $T_{\text{amb}} = 70^\circ\text{C}$ Pin 7 to 15	$-I_{0R}$			50	$\mu\text{A}$
Output voltage level Logic "0" Logic "1"	Pin 7 to 15	$-V_{OH}$ $-V_{OL}$	10.8		2.0	V V
Output current	$-V_{OH} = 2\text{ V}$ , $T_{\text{amb}} = 25^\circ\text{C}$ Pin 7 to 15 $T_{\text{amb}} = 7^\circ\text{C}$ Pin 7 to 15	$-I_O$ $-I_O$	12 10			mA mA
Input voltage level Logic "0" Logic "1"	Pin 2 to 6	$-V_{IH}$ $-V_{IL}$	-0.3 13.2		+1 4.0	V V
Input currents	$-V_{IL} = 4.0\text{ V}$ $-V_{IH} = 1.0\text{ V}$ Pin 2 to 6	$-I_{IL}$ $-I_{IH}$	10		120	$\mu\text{A}$ $\mu\text{A}$

## Truth Table

Number displayed	Inputs					Outputs										
	D	C	B	A	DS	a	b	c	d	e	f	g	h	i		
1	L	L	L	L	H	L	H	H	L	L	L	L	L	L		
2	L	L	L	H	H	H	H	L	H	H	L	H	L	L		
3	L	L	H	L	H	H	H	H	H	L	L	H	L	L		
4	L	L	H	H	H	L	H	H	L	L	H	H	L	L		
5	L	H	L	L	H	H	L	H	H	L	H	H	L	L		
6	L	H	L	H	H	H	L	H	H	H	H	H	L	L		
7	L	H	H	L	H	H	H	H	L	L	L	L	L	L		
8	L	H	H	H	H	H	H	H	H	H	H	H	L	L		
9	H	L	L	L	H	H	H	H	H	L	H	H	L	L		
10	H	L	L	H	H	H	H	H	H	H	H	L	H	H		
11	H	L	H	L	H	L	H	H	L	L	L	L	H	H		
12	H	L	H	H	H	H	H	L	H	H	L	H	H	H		
13	H	H	L	L	H	H	H	H	H	L	L	H	H	H		
14	H	H	L	H	H	L	H	H	L	L	H	H	H	H		
15	H	H	H	L	H	H	L	H	H	L	H	H	H	H		
16	H	H	H	H	H	H	L	H	H	H	H	H	H	H		
dark	X	X	X	X	L	L	L	L	L	L	L	L	L	L		



## Ozone Depleting Substances Policy Statement

It is the policy of **TEMIC TELEFUNKEN microelectronic GmbH** to

1. Meet all present and future national and international statutory requirements.
2. Regularly and continuously improve the performance of our products, processes, distribution and operating systems with respect to their impact on the health and safety of our employees and the public, as well as their impact on the environment.

It is particular concern to control or eliminate releases of those substances into the atmosphere which are known as ozone depleting substances (ODSs).

The Montreal Protocol (1987) and its London Amendments (1990) intend to severely restrict the use of ODSs and forbid their use within the next ten years. Various national and international initiatives are pressing for an earlier ban on these substances.

**TEMIC TELEFUNKEN microelectronic GmbH** semiconductor division has been able to use its policy of continuous improvements to eliminate the use of ODSs listed in the following documents.

1. Annex A, B and list of transitional substances of the Montreal Protocol and the London Amendments respectively
2. Class I and II ozone depleting substances in the Clean Air Act Amendments of 1990 by the Environmental Protection Agency (EPA) in the USA
3. Council Decision 88/540/EEC and 91/690/EEC Annex A, B and C (transitional substances) respectively.

**TEMIC** can certify that our semiconductors are not manufactured with ozone depleting substances and do not contain such substances.

**We reserve the right to make changes to improve technical design and may do so without further notice.**

Parameters can vary in different applications. All operating parameters must be validated for each customer application by the customer. Should the buyer use TEMIC products for any unintended or unauthorized application, the buyer shall indemnify TEMIC against all claims, costs, damages, and expenses, arising out of, directly or indirectly, any claim of personal damage, injury or death associated with such unintended or unauthorized use.

TEMIC TELEFUNKEN microelectronic GmbH, P.O.B. 3535, D-74025 Heilbronn, Germany  
Telephone: 49 (0)7131 67 2831, Fax number: 49 (0)7131 67 2423